

Explosionszeichnungen Kawasaki Z1000

Kopie von der US-Kawasaki Seite

- | | |
|---|------------------------------------|
| 1. Anlasser | 32. Kurbelgehäuse + Bolzenposition |
| 2. Armatureneinheit | 33. Kurbelgehäuse |
| 3. Aufkleber grün | 34. Kurbelwelle |
| 4. Aufkleber orange | 35. Lenker |
| 5. Aufkleber schwarz | 36. Lichtmaschine |
| 6. Auspuffanlage | 37. Luftfilter |
| 7. Benzinleitungen + Anschlüsse | 38. Motoraufhängung |
| 8. Benzinpumpe | 39. Motordeckel |
| 9. Bereifung | 40. Nockenwelle + Kettenspanner |
| 10. Blinker | 41. Ölpumpe + Ölfilter |
| 11. Bordwerkzeug | 42. Ölwanne |
| 12. Bowdenzüge | 43. Optionale Teile |
| 13. Bremspedal | 44. Rahmen |
| 14. Bremszylinder hinten | 45. Rahmentelle |
| 15. Bremszylinder vorne | 46. Rücklicht |
| 16. Drosselklappen | 47. Schaltgestänge + Schalteinheit |
| 17. Einspritzanlage | 48. Schaltgestänge + Anschlüsse |
| 18. Federbein hinten | 49. Seitenständer |
| 19. Federbeinaufnahme | 50. Sitzbank |
| 20. Frontscheinwerfer | 51. Tank |
| 21. Frontverkleidung | 52. Ventile |
| 22. Fussrastenanlage | 53. Verkabelung |
| 23. Gabel | 54. Vorderbremse |
| 24. Getriebe | 55. Vorderrad |
| 25. Heckverkleidung, Seitendeckel, Kettenschutz | 56. Wamaufkleber |
| 26. Hinterbremse | 57. Zündanlage |
| 27. Hinterrad + Ritzel | 58. Zündschloss |
| 28. Hinterradschwinge | 59. Zylinder + Kolben |
| 29. Kotflügel | 60. Zylinderkopf |
| 30. Kühler + Ventilator | 61. Zylinderkopfdeckel |
| 31. Kupplung | |

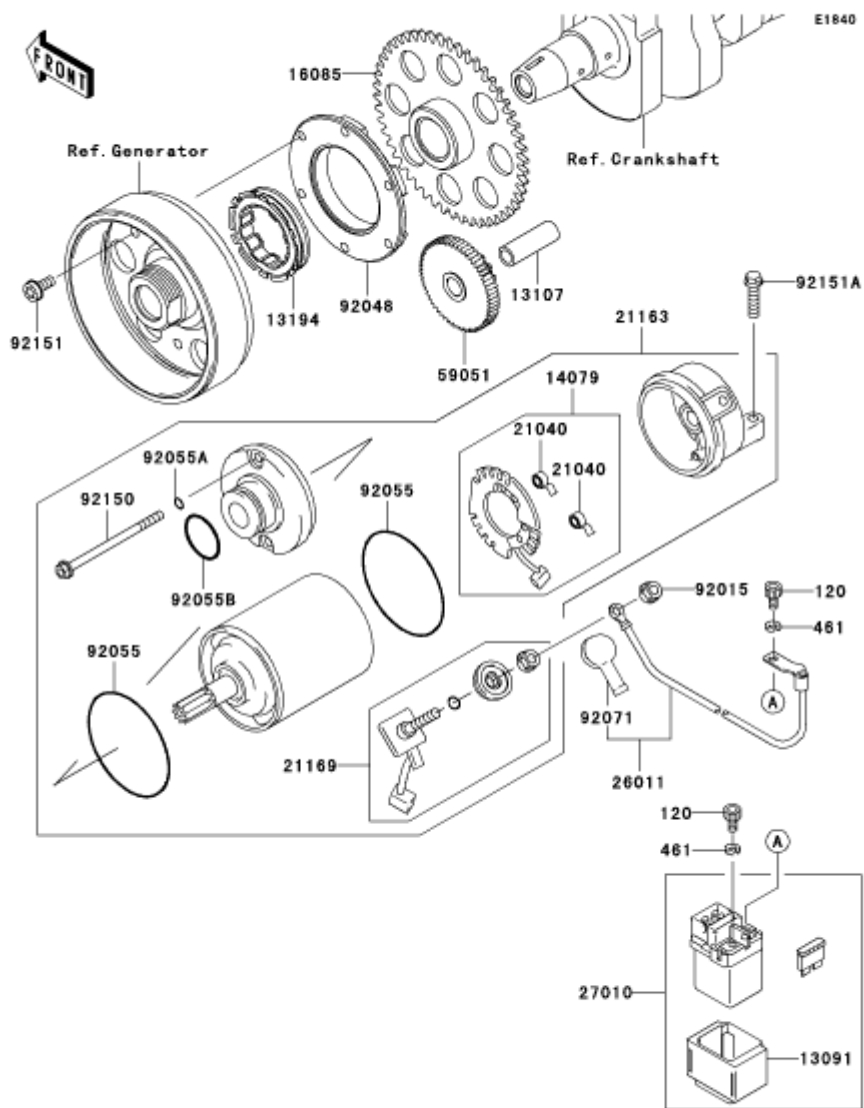

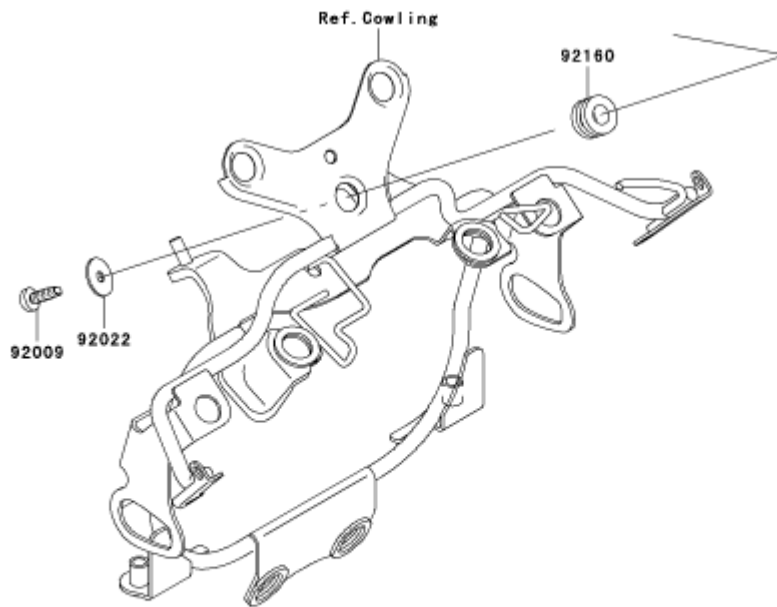
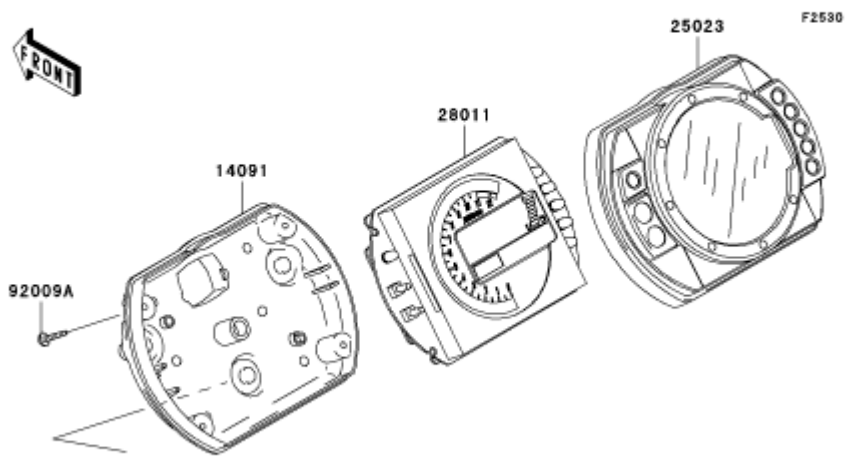

F2881A

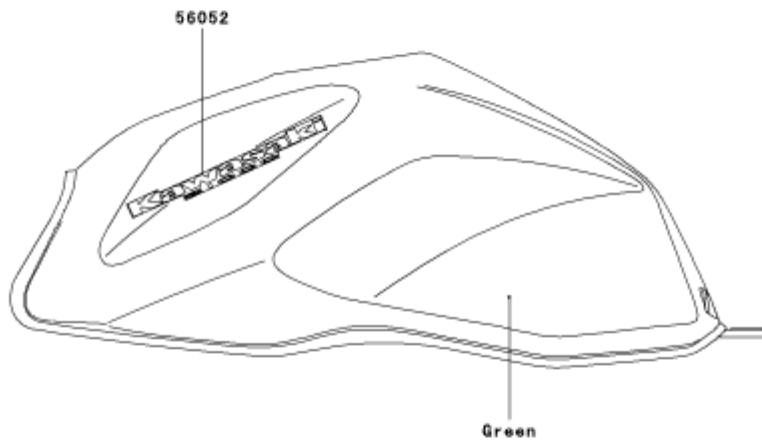

F2881B

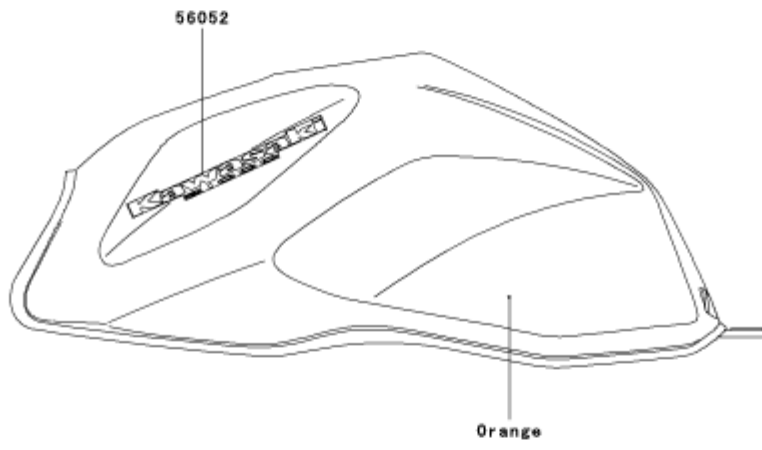

F2861

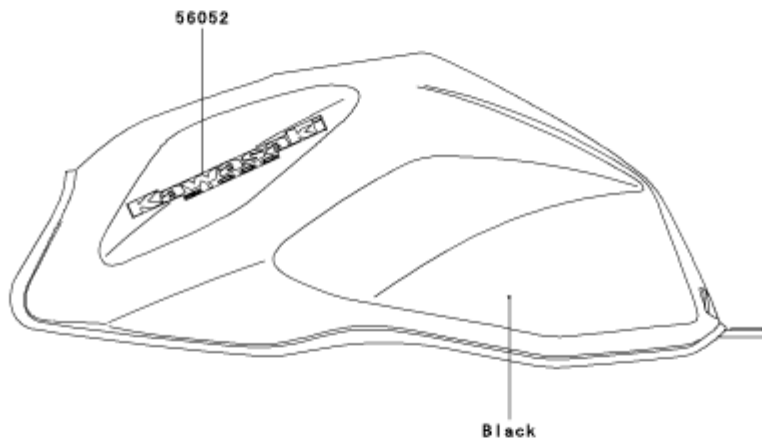

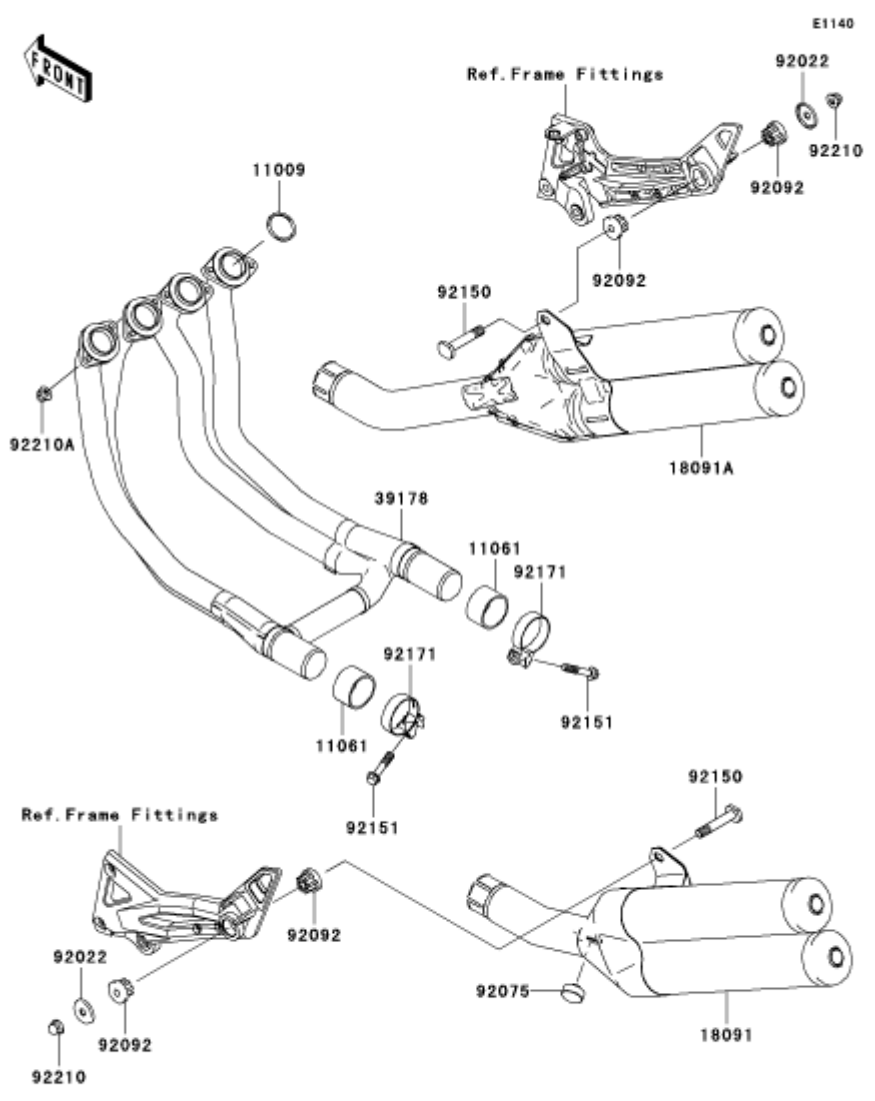

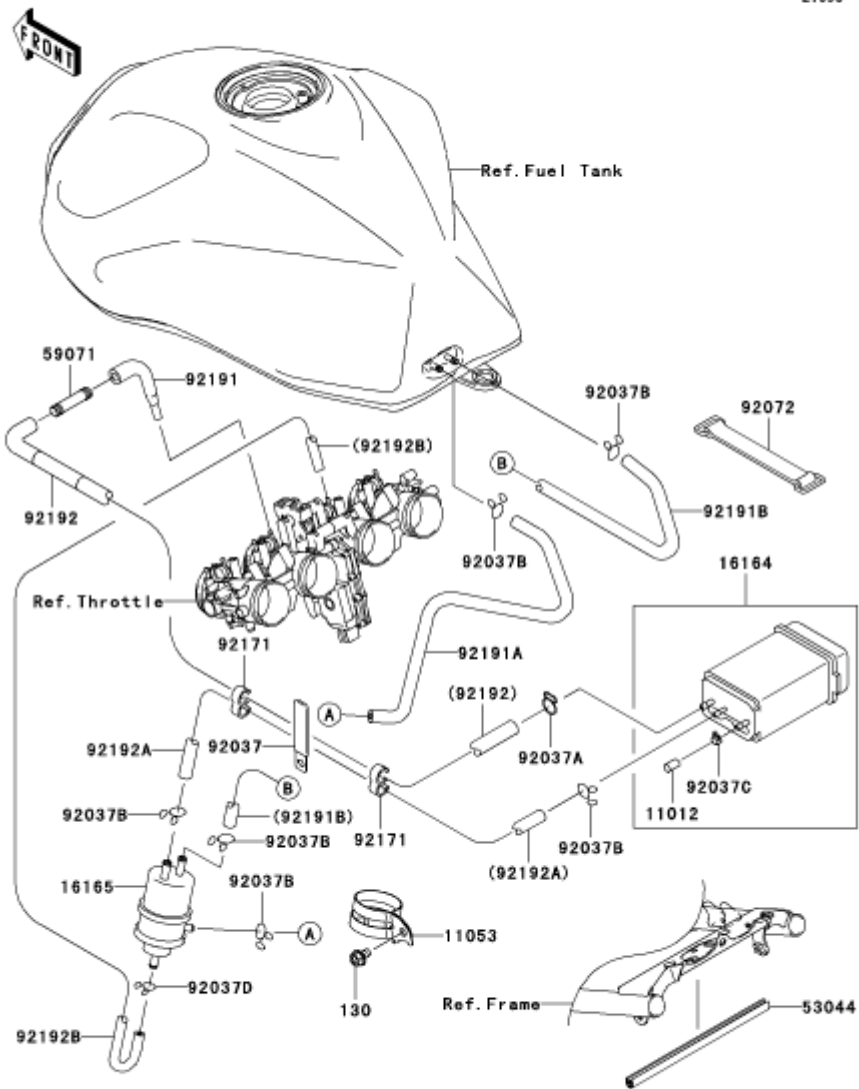

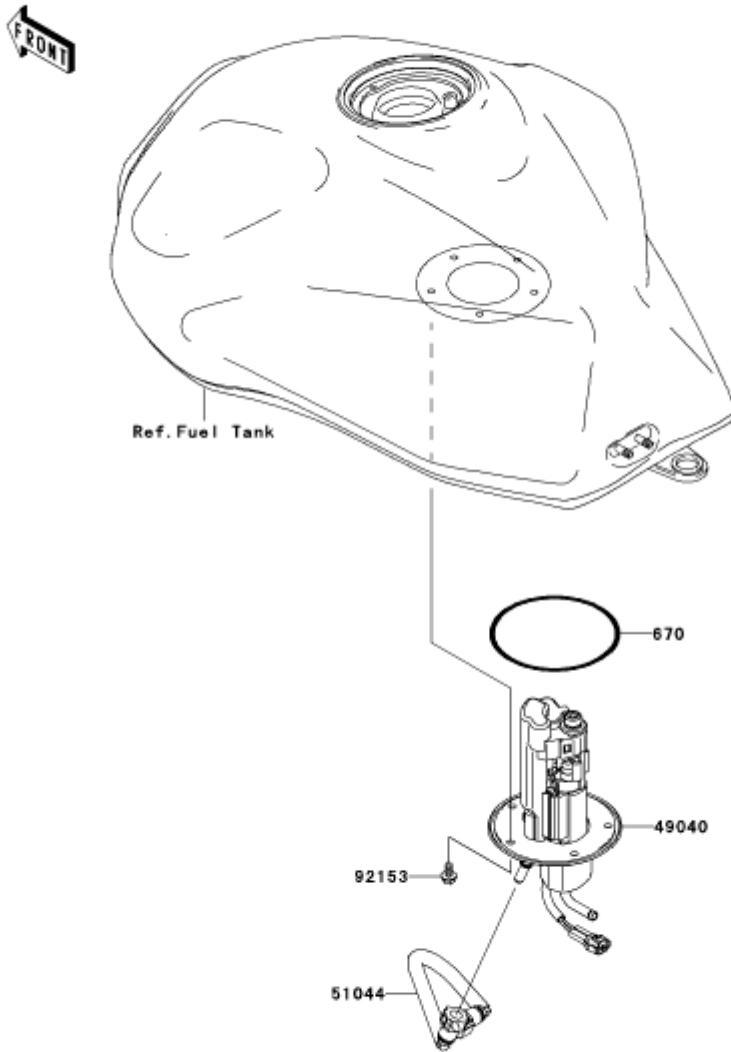

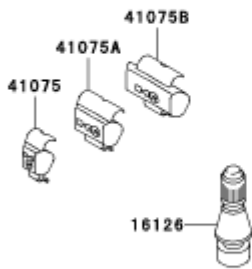
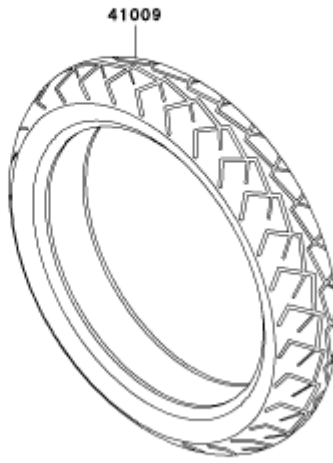
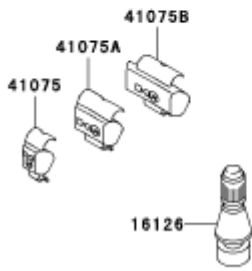

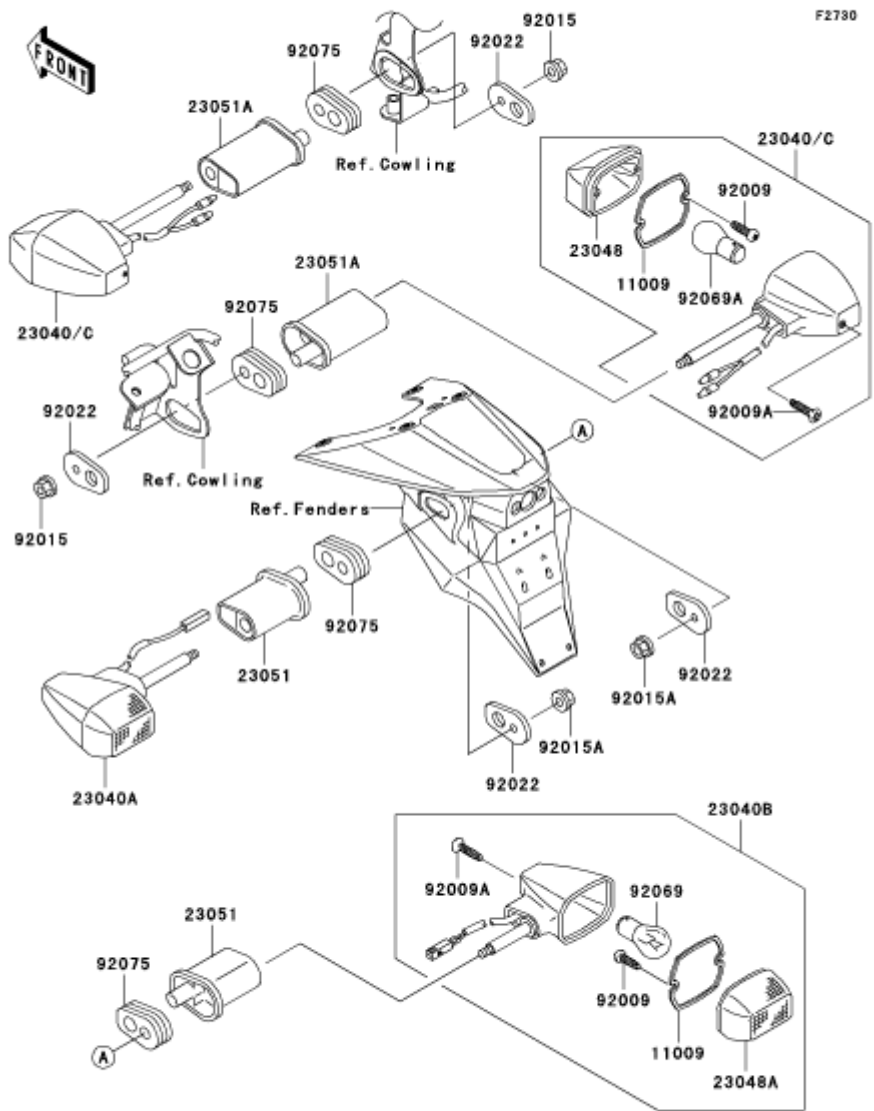

56007

F2810

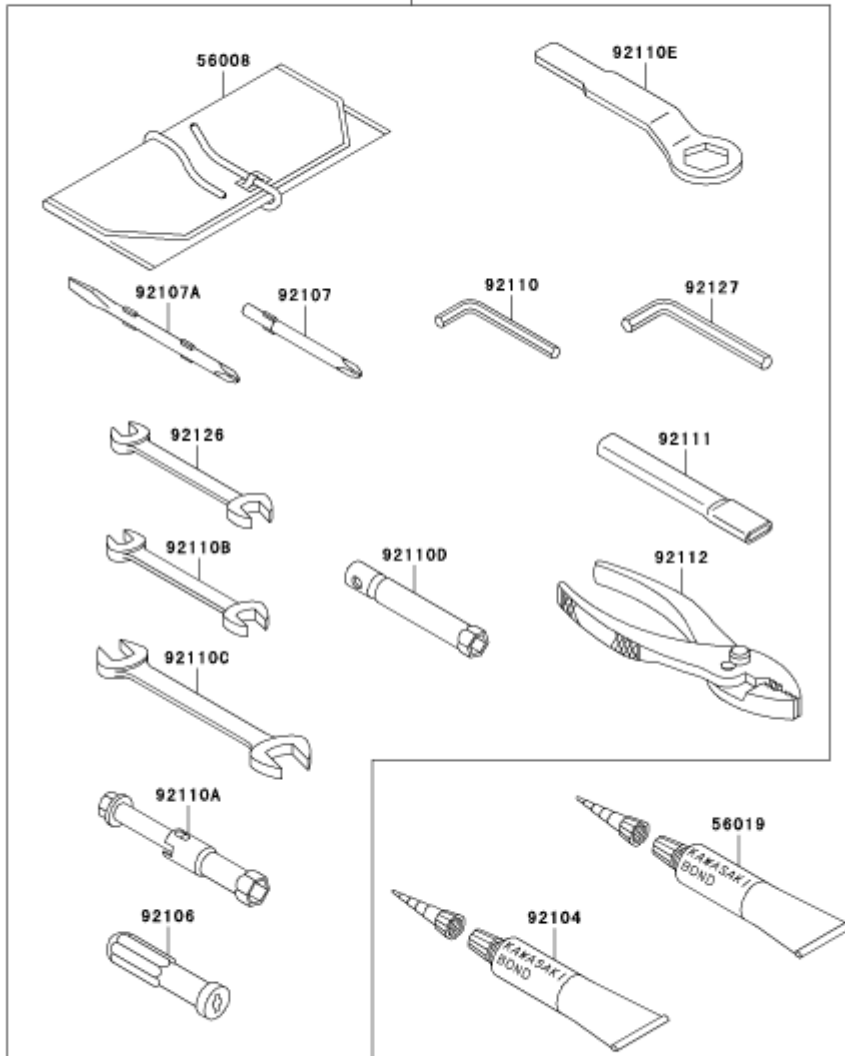

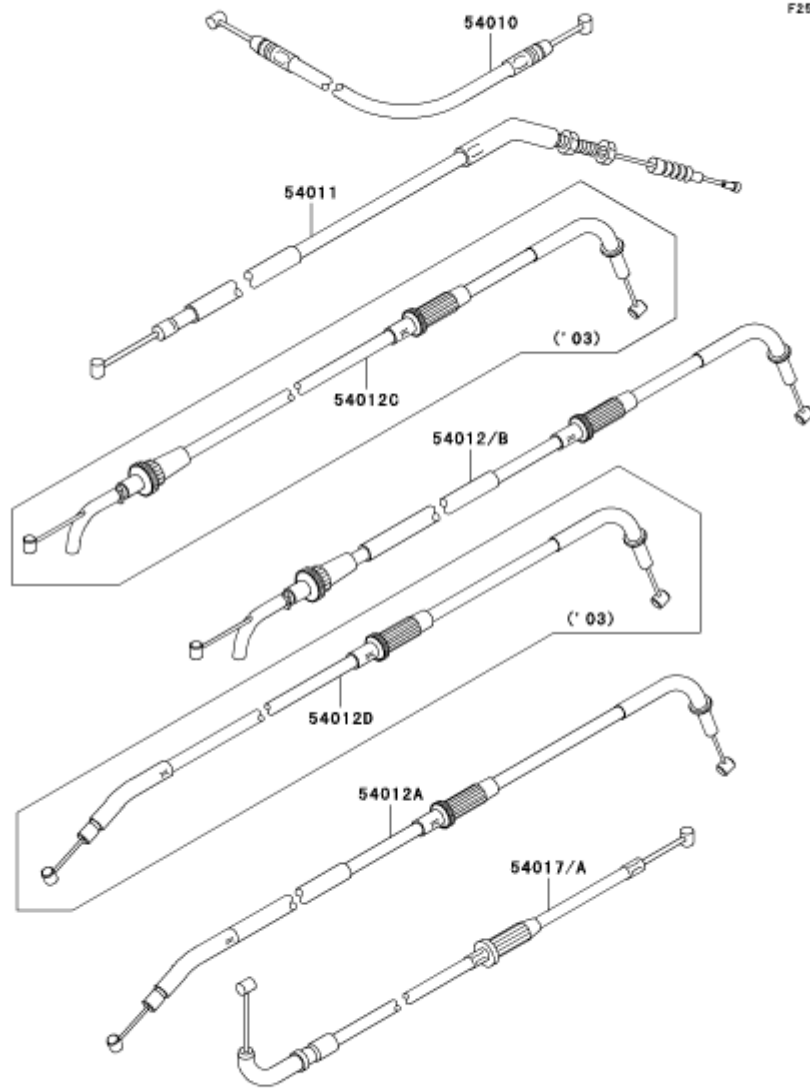

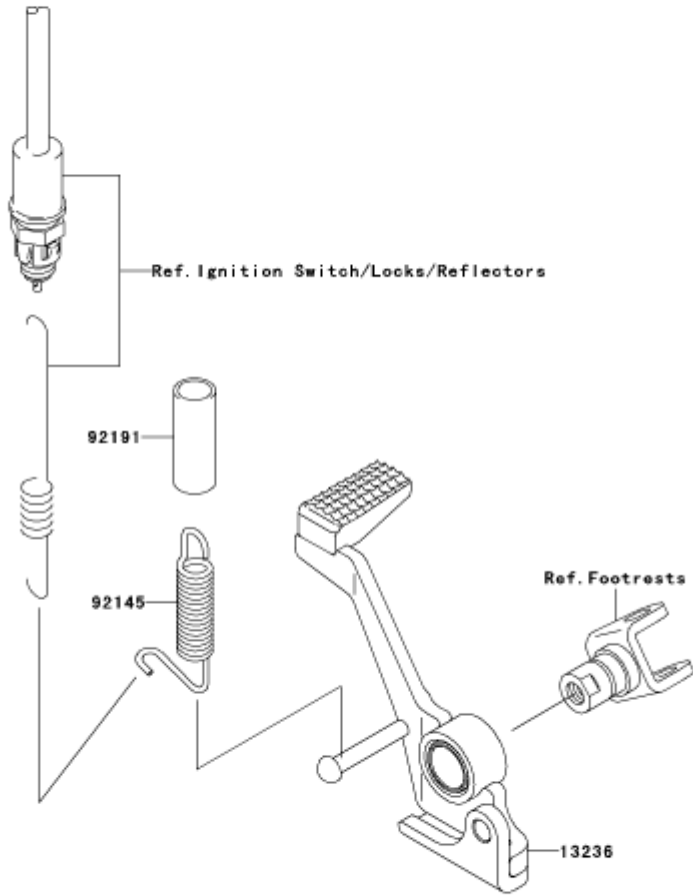

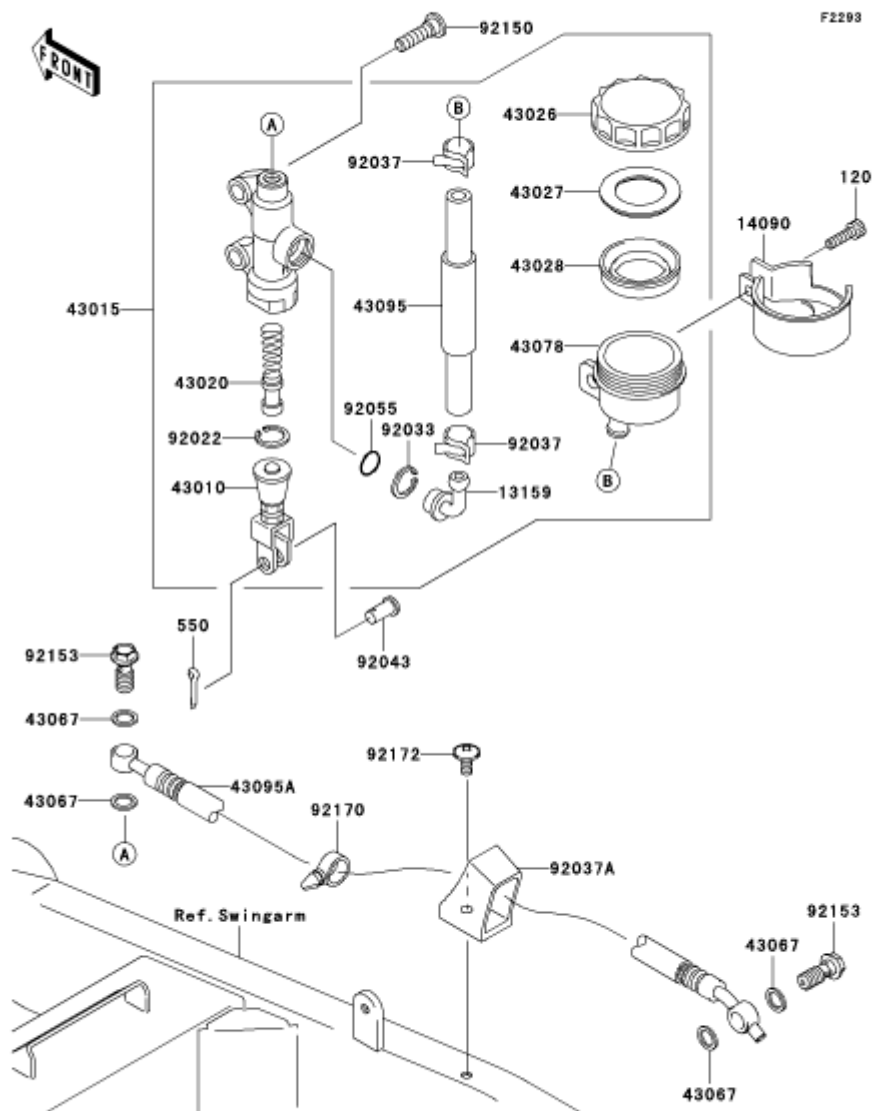

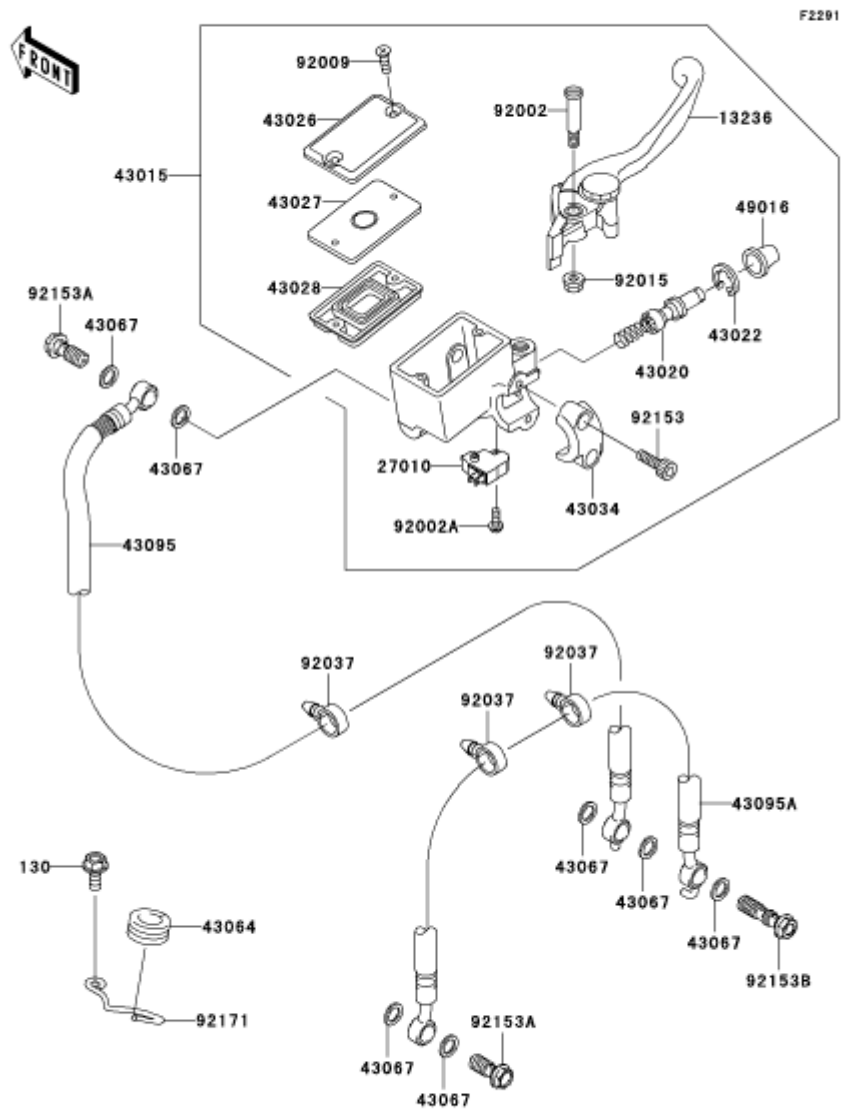

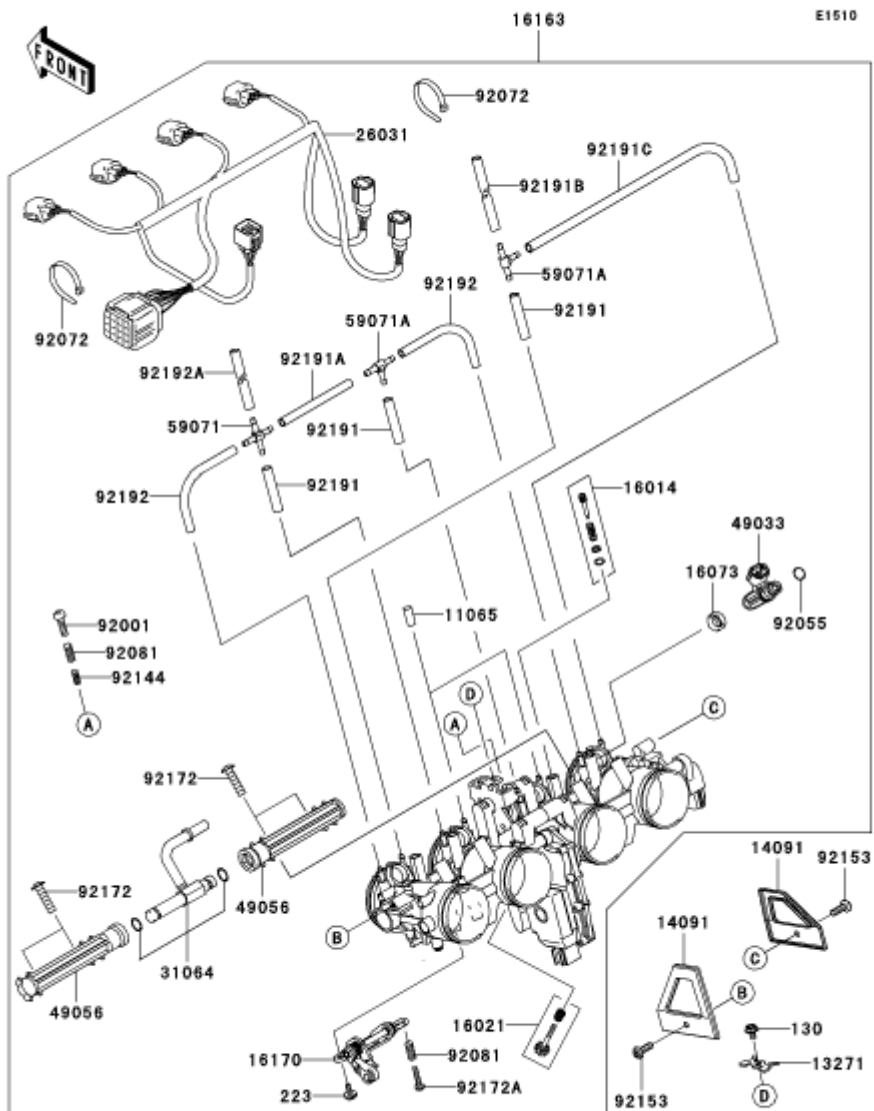

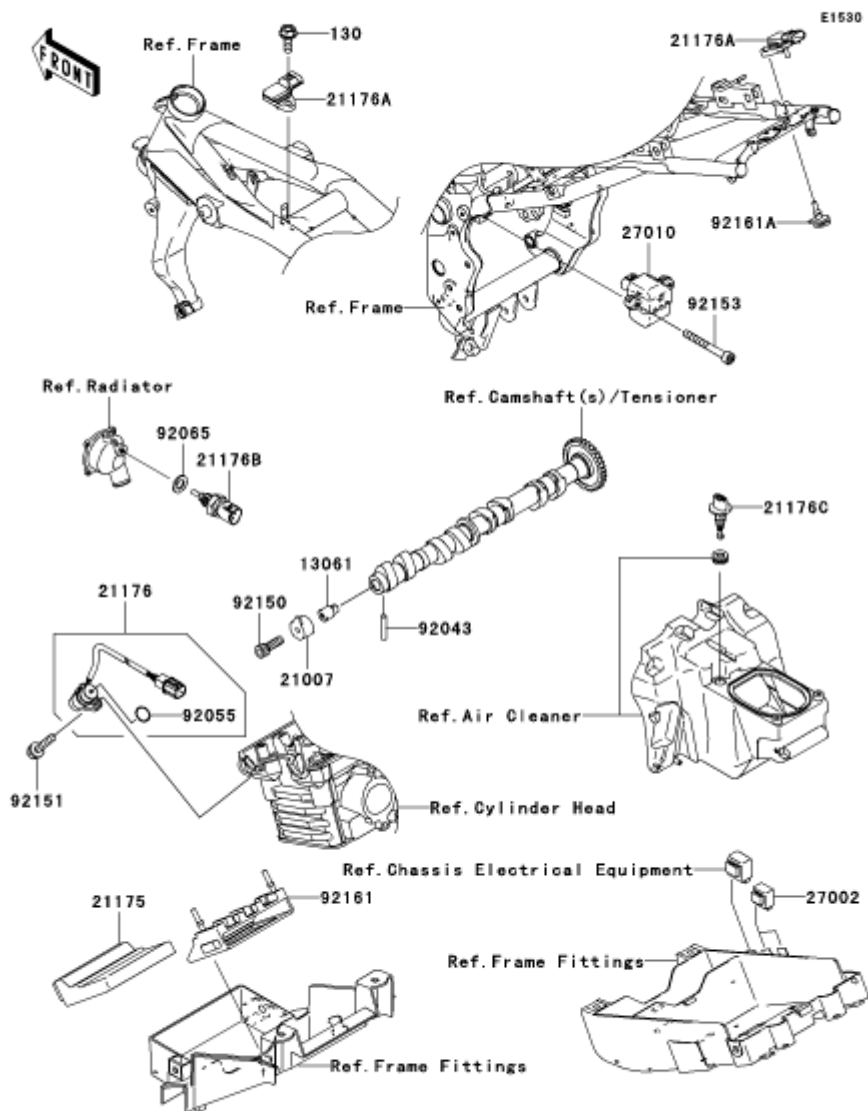

F2280

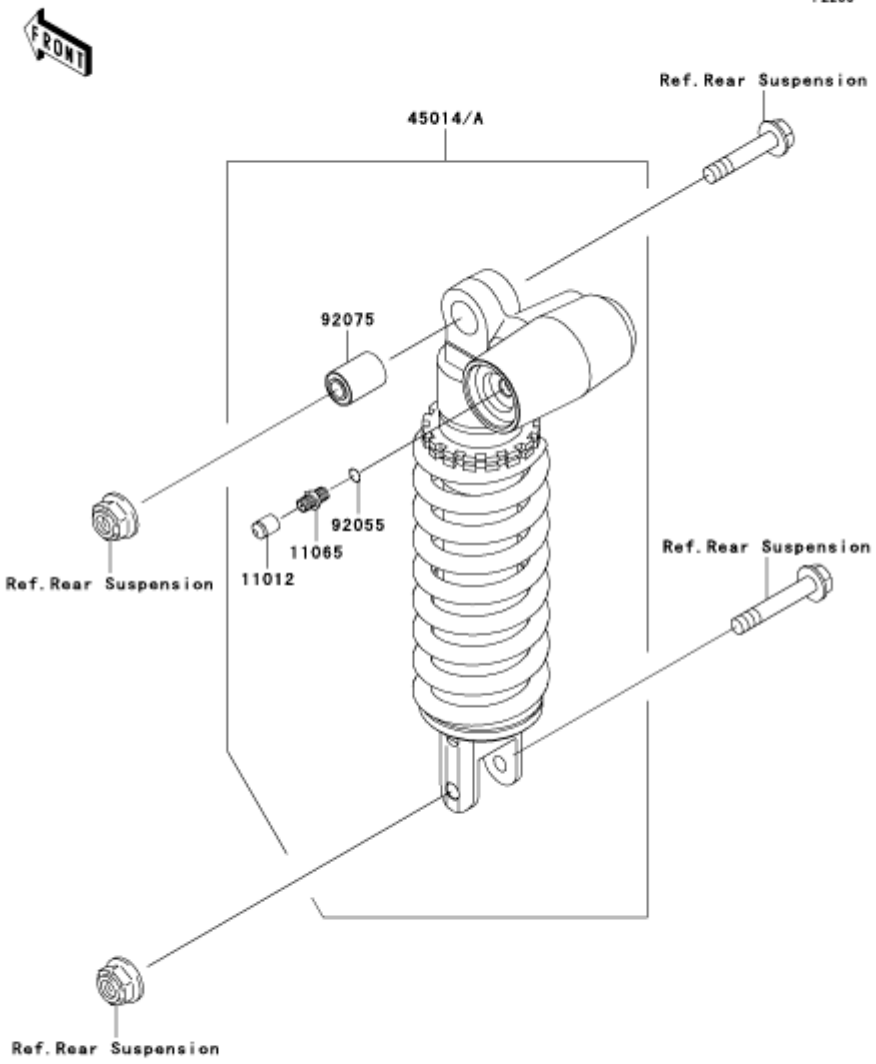

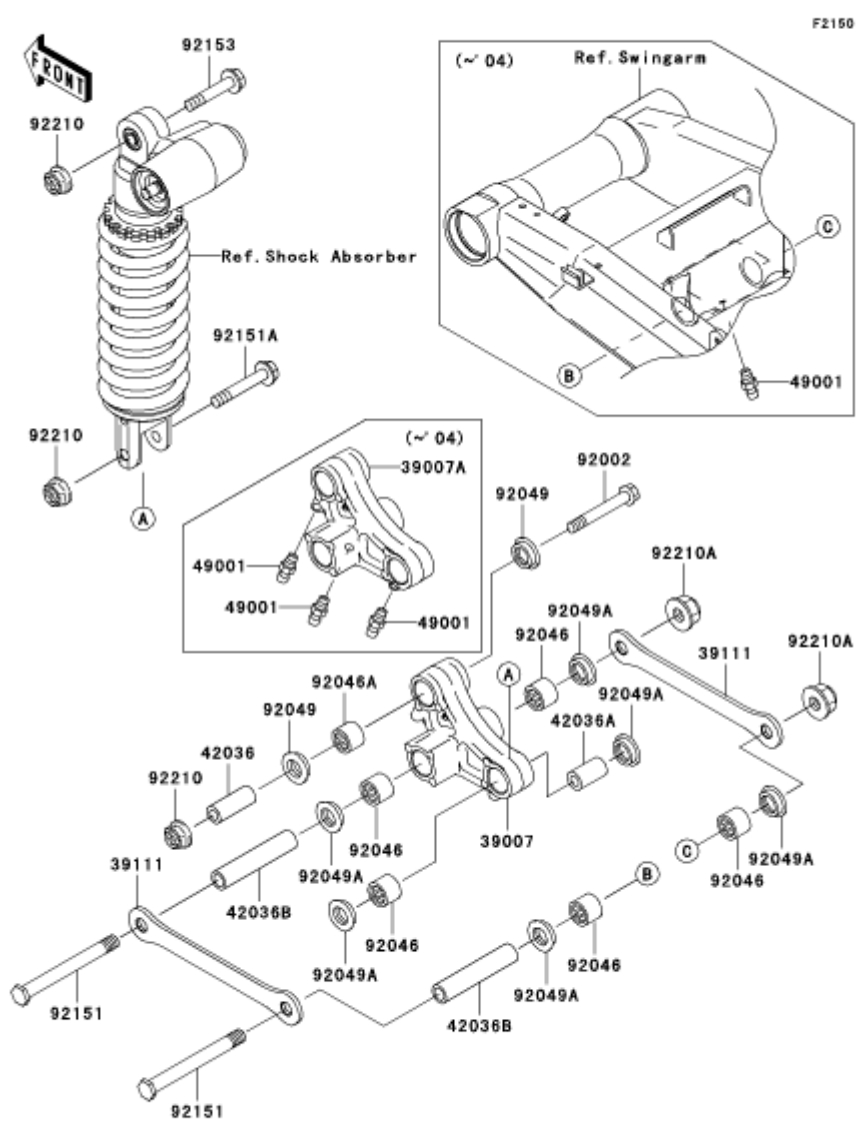

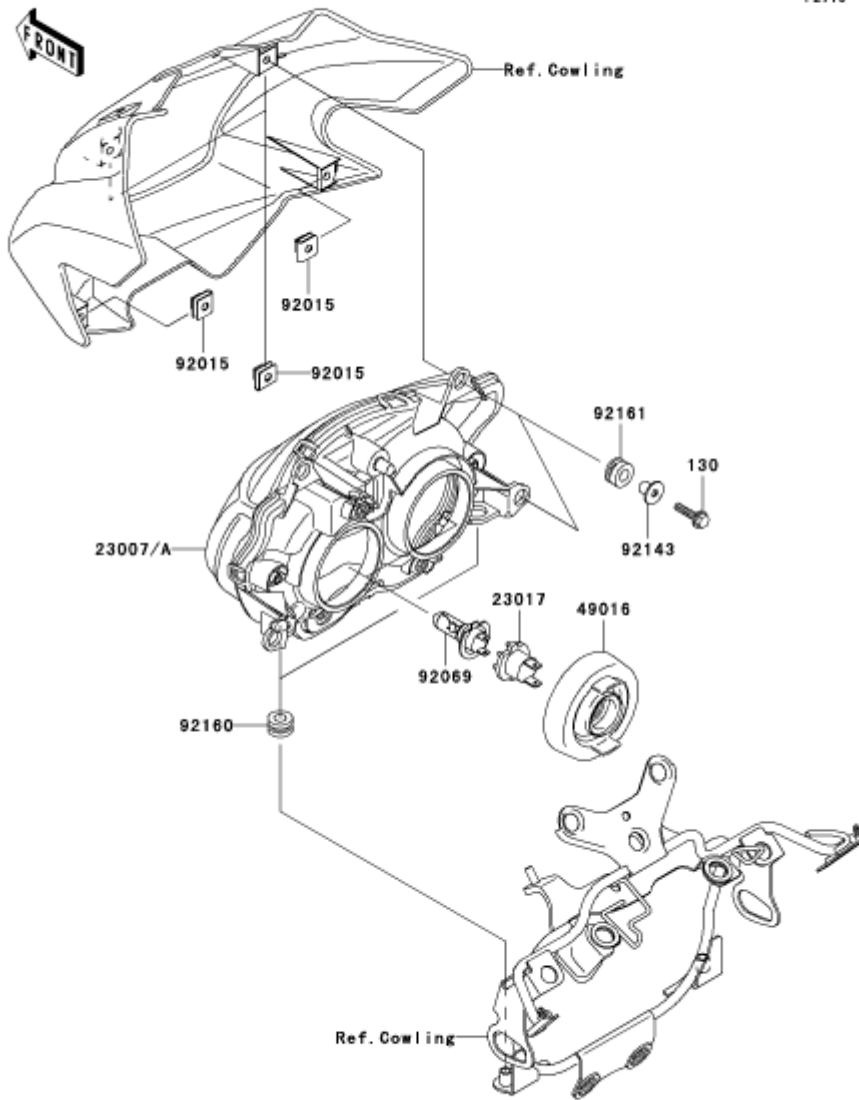

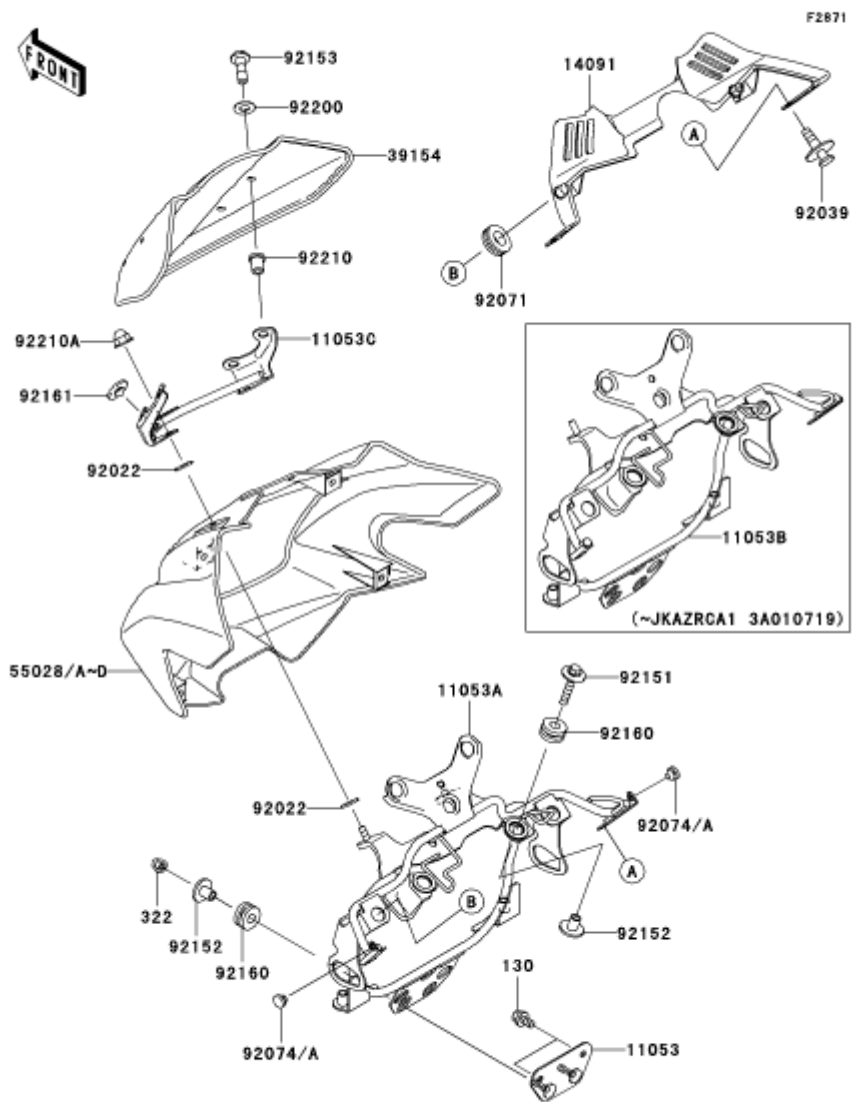

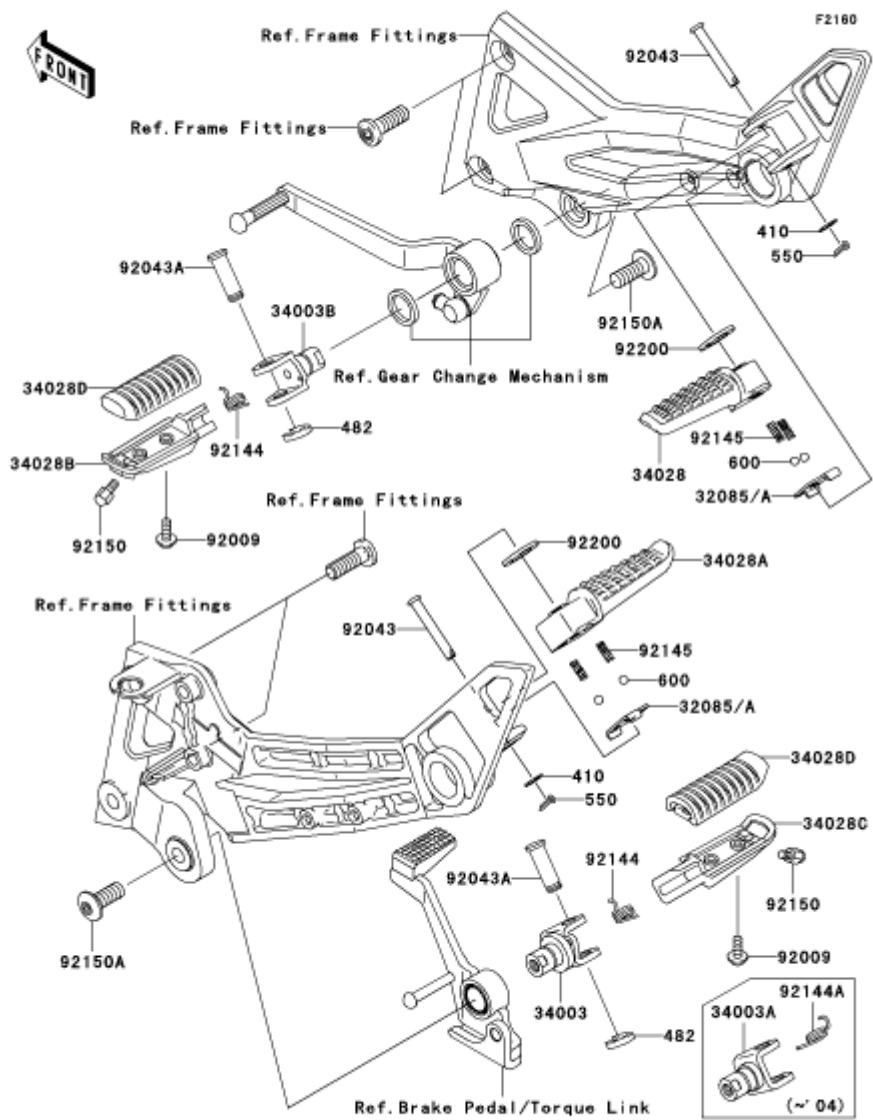

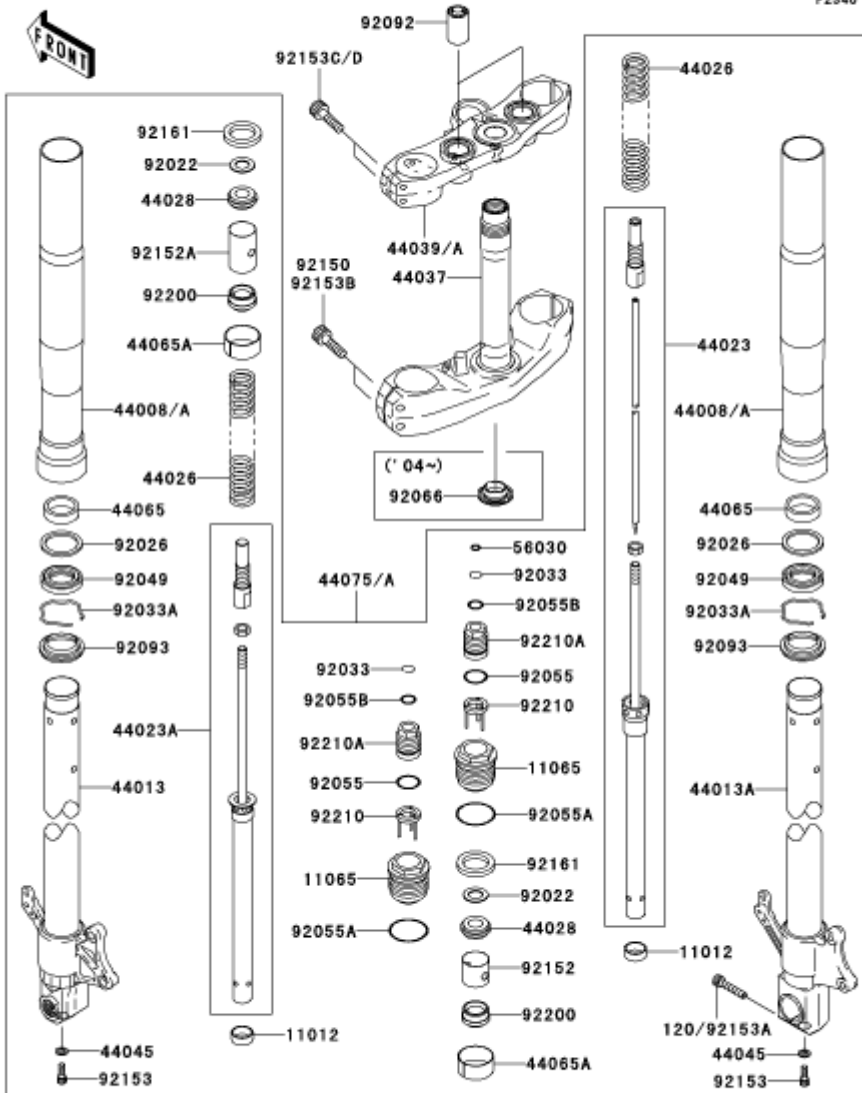

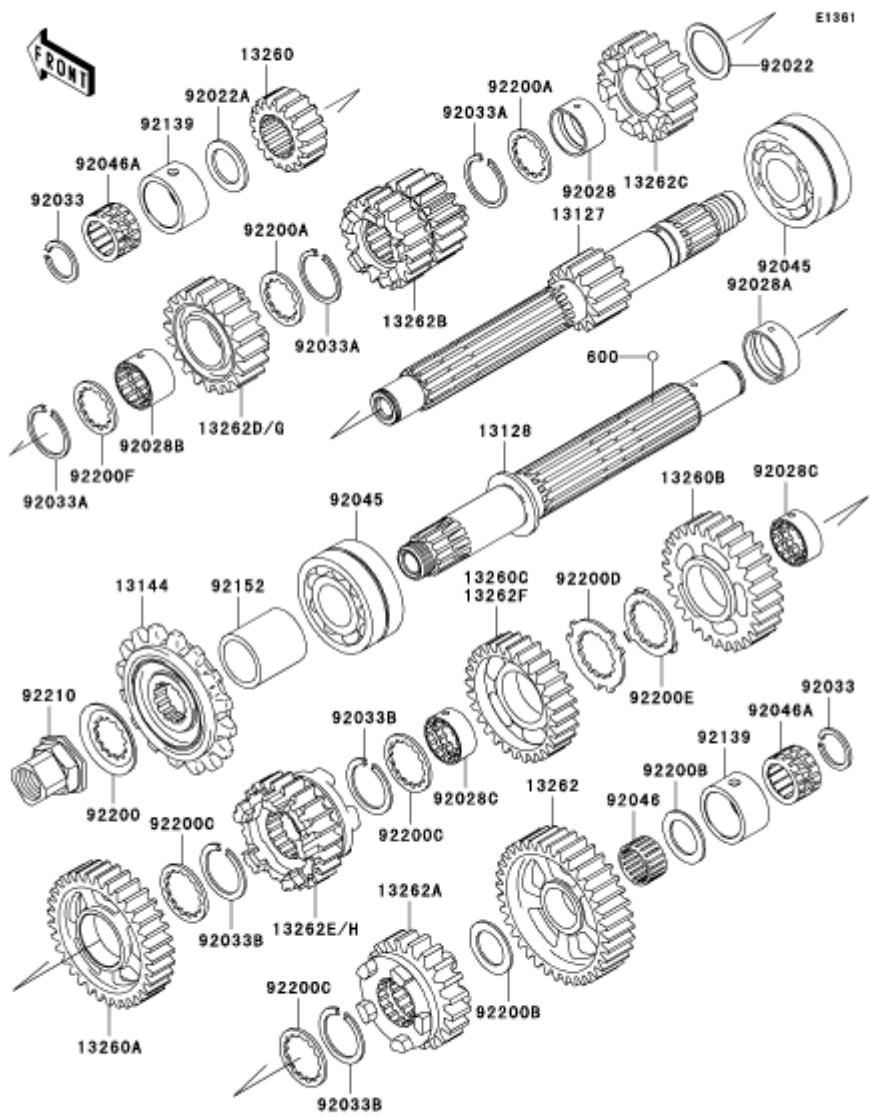

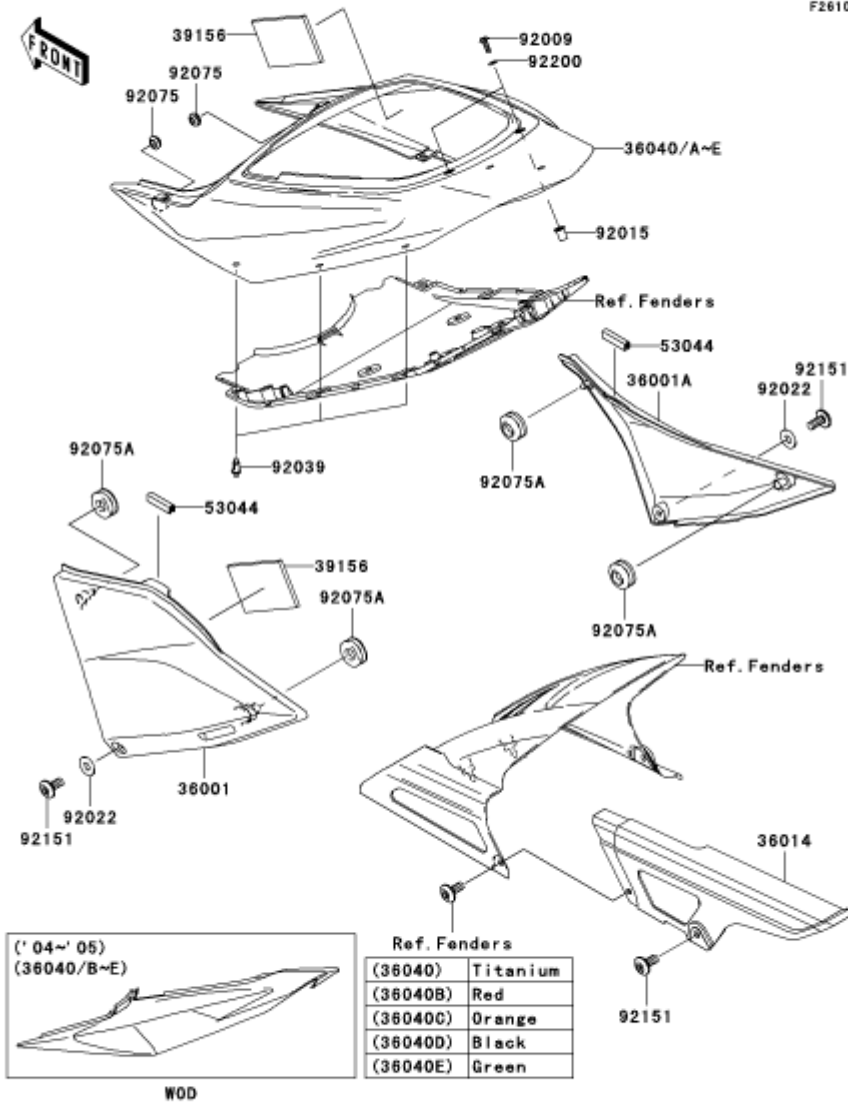

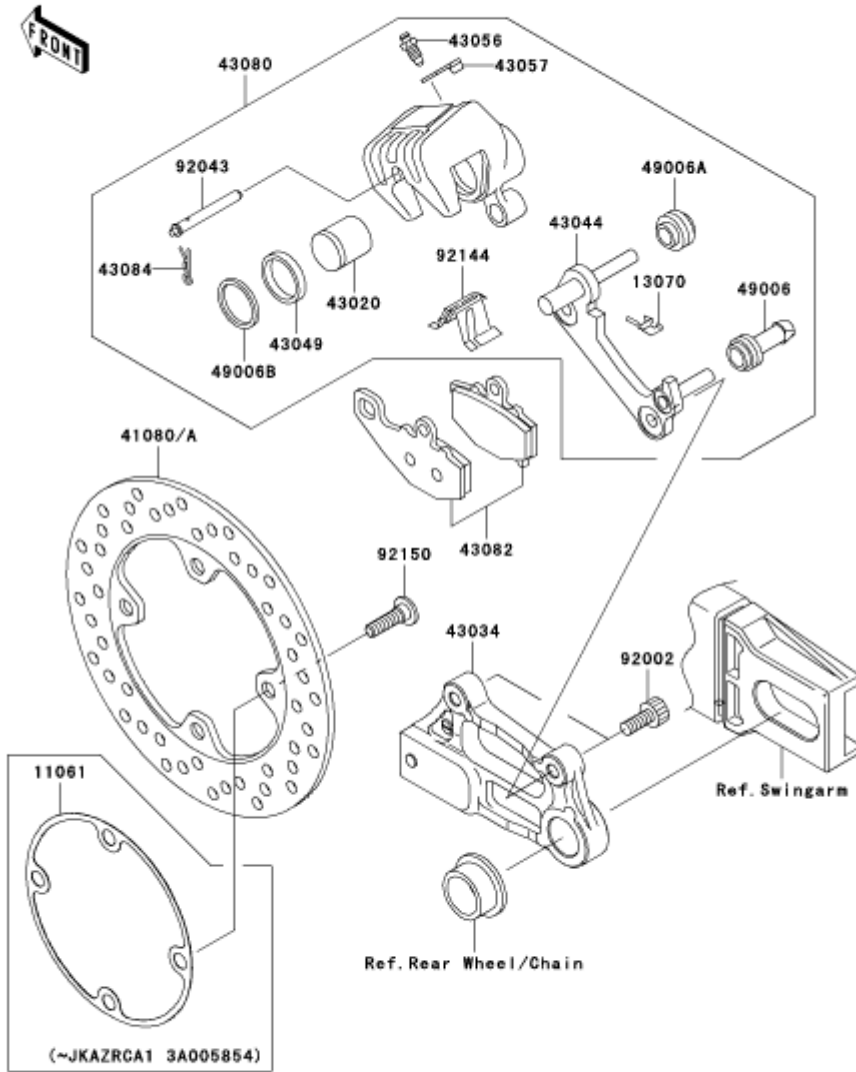

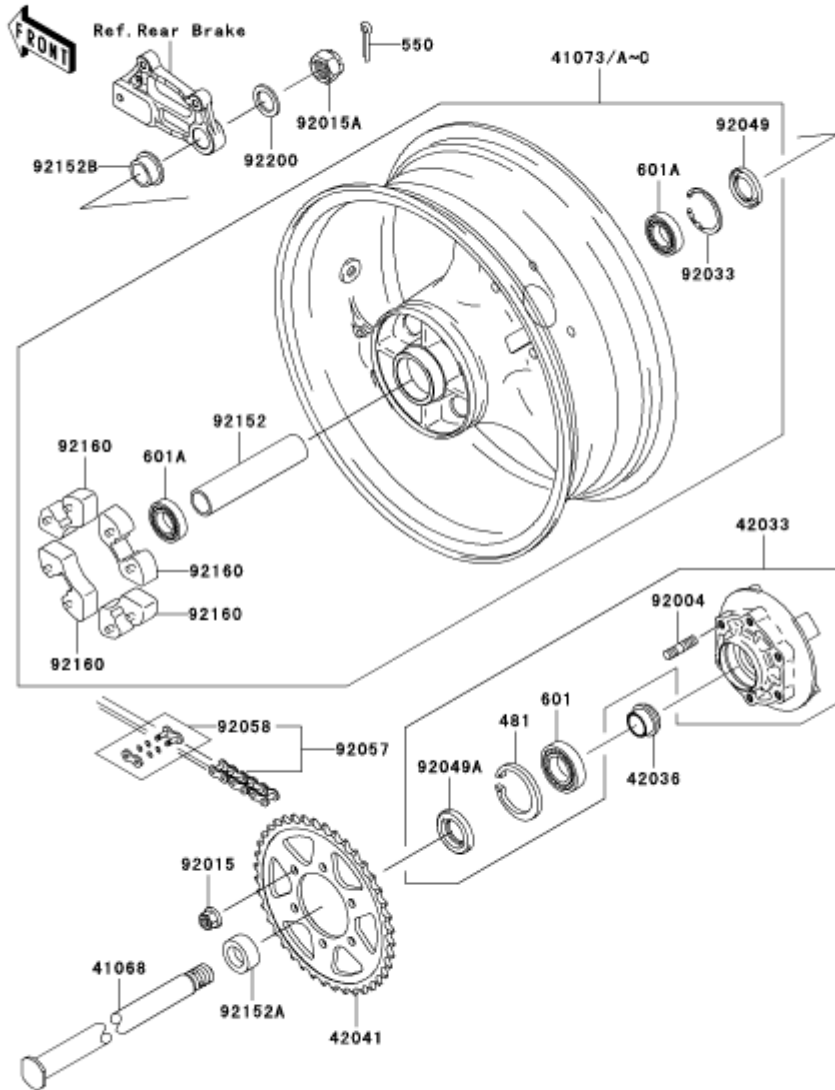

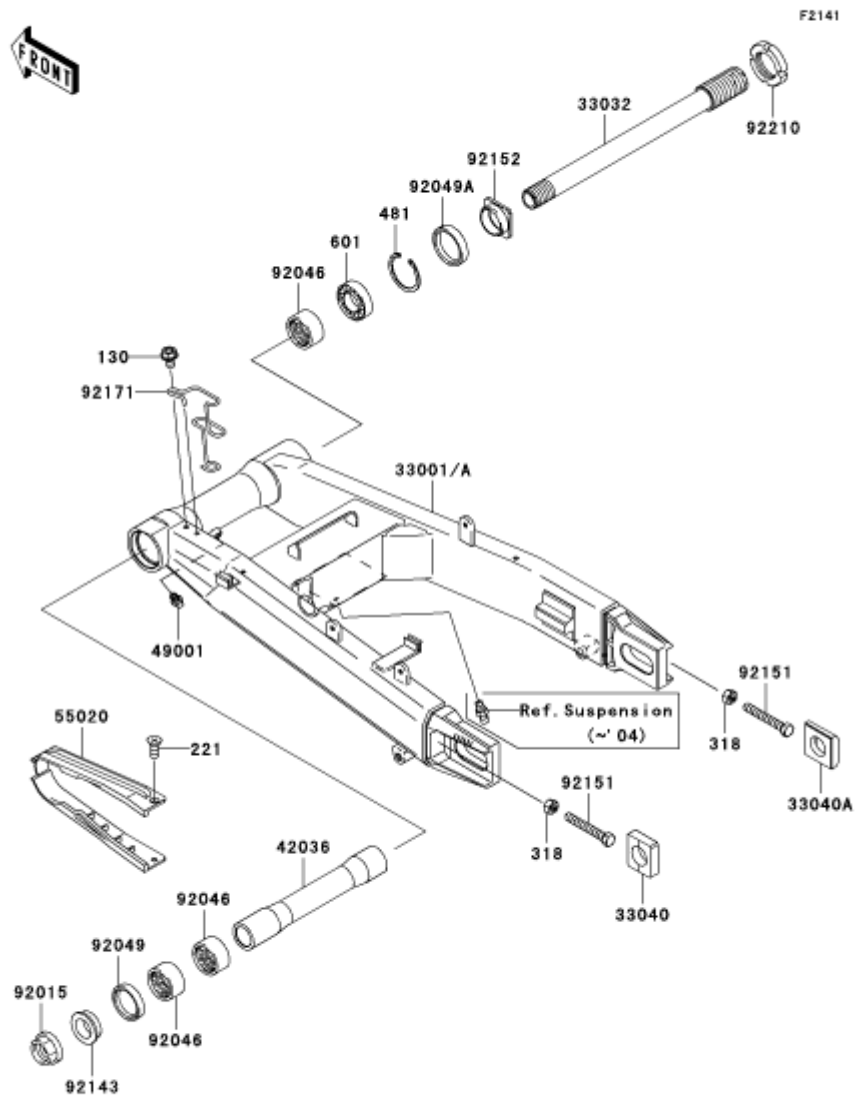

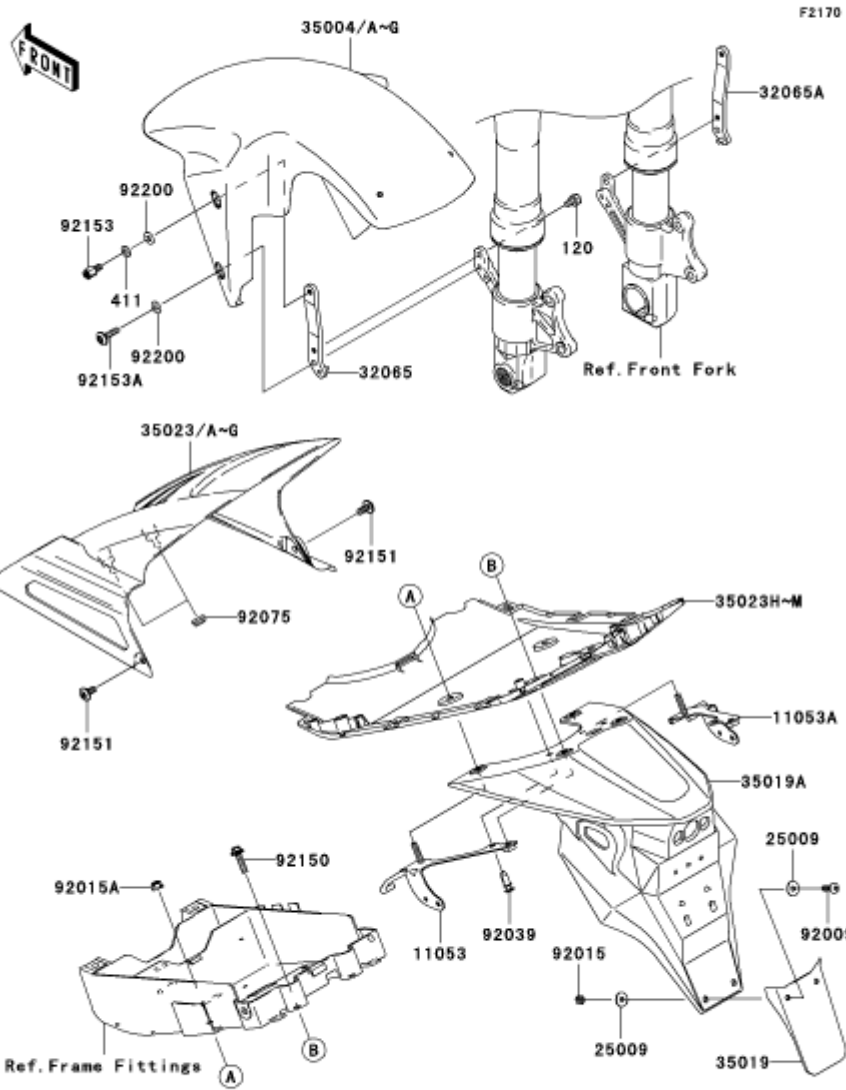

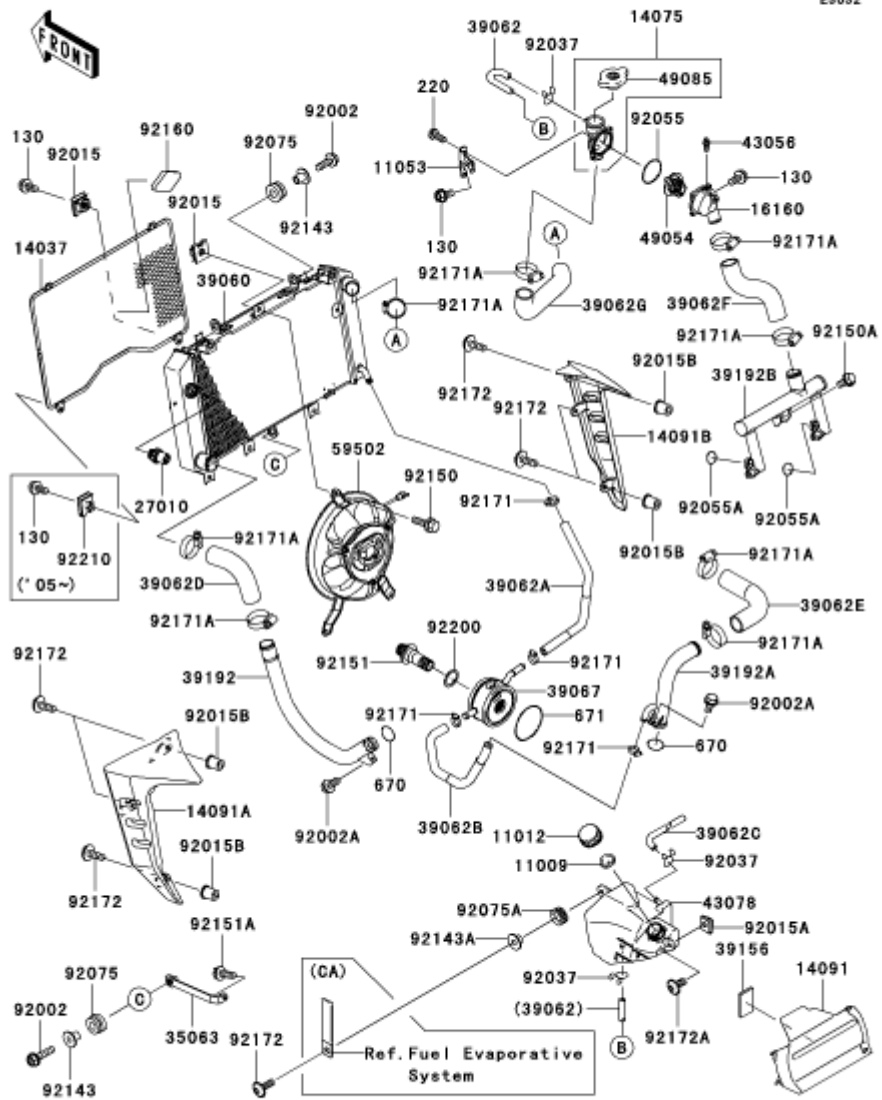

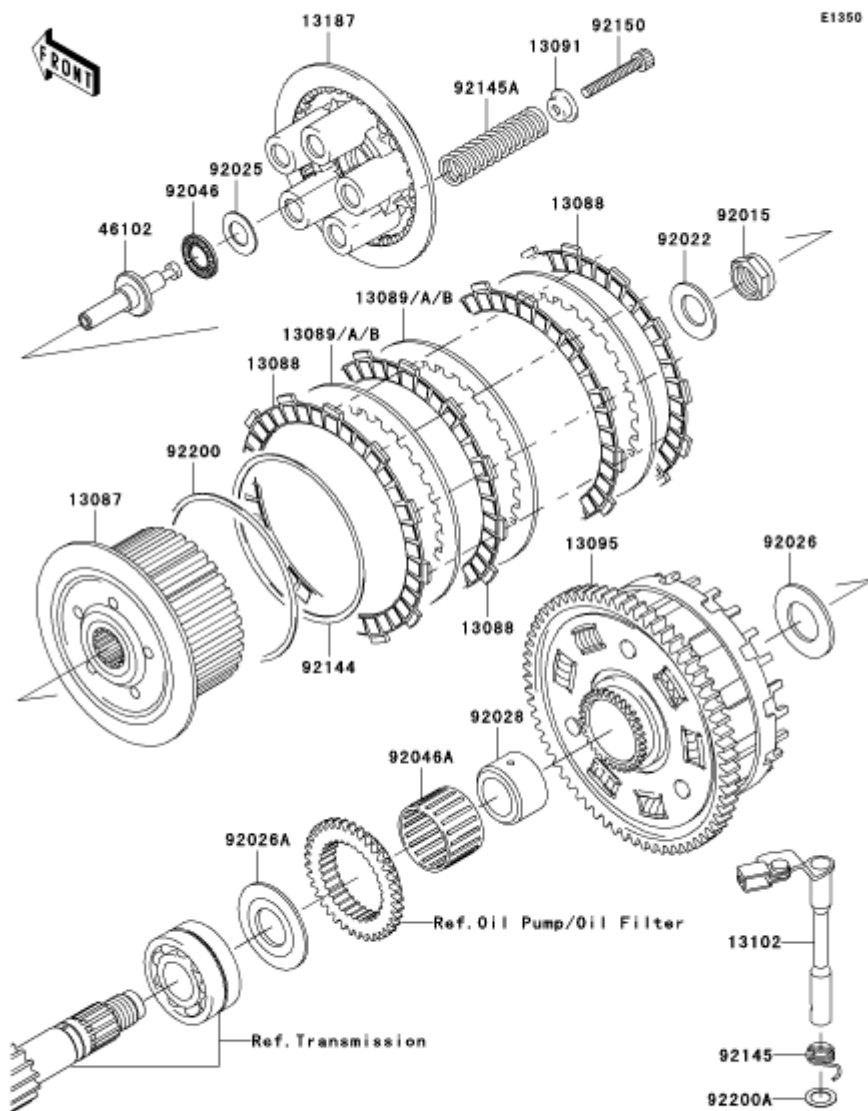

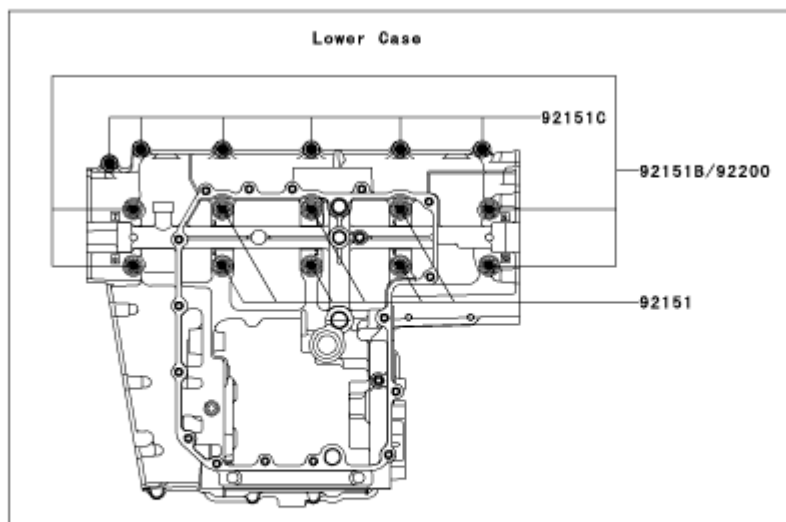
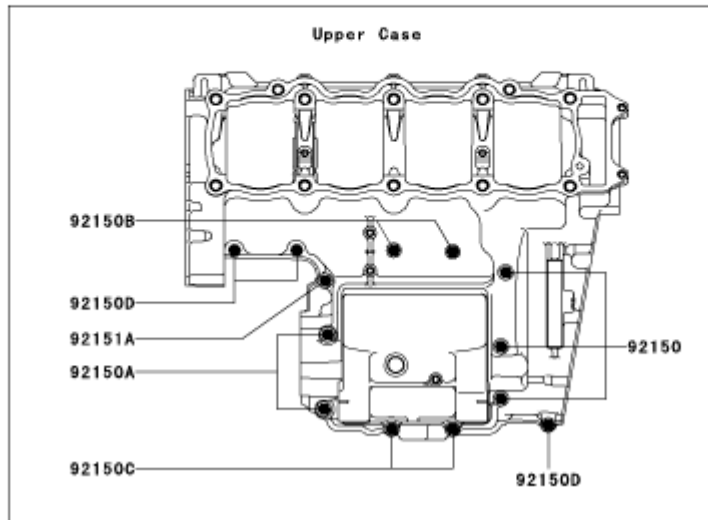

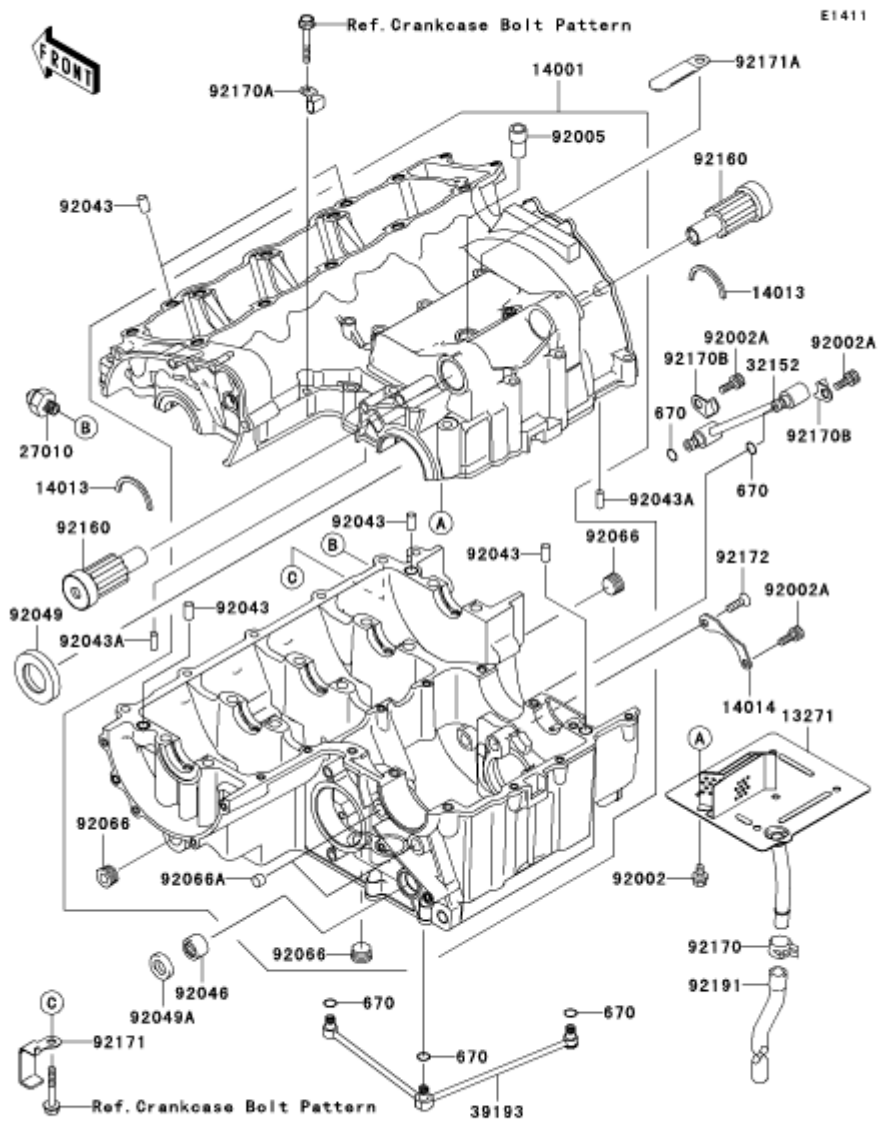

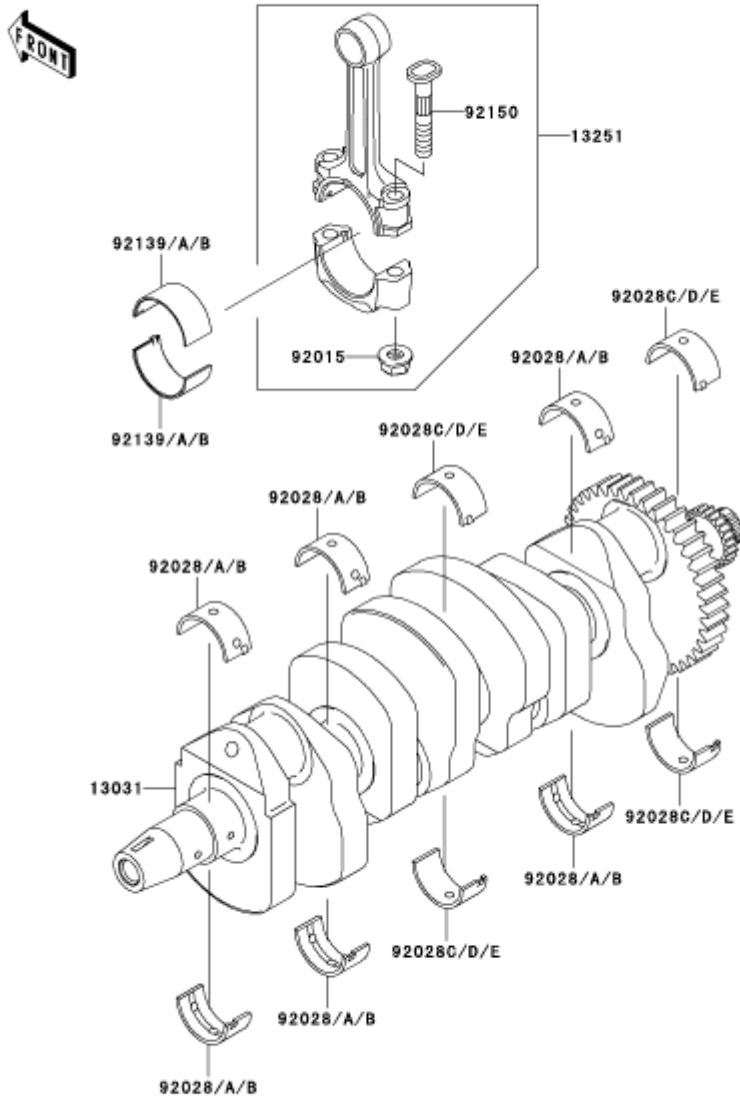

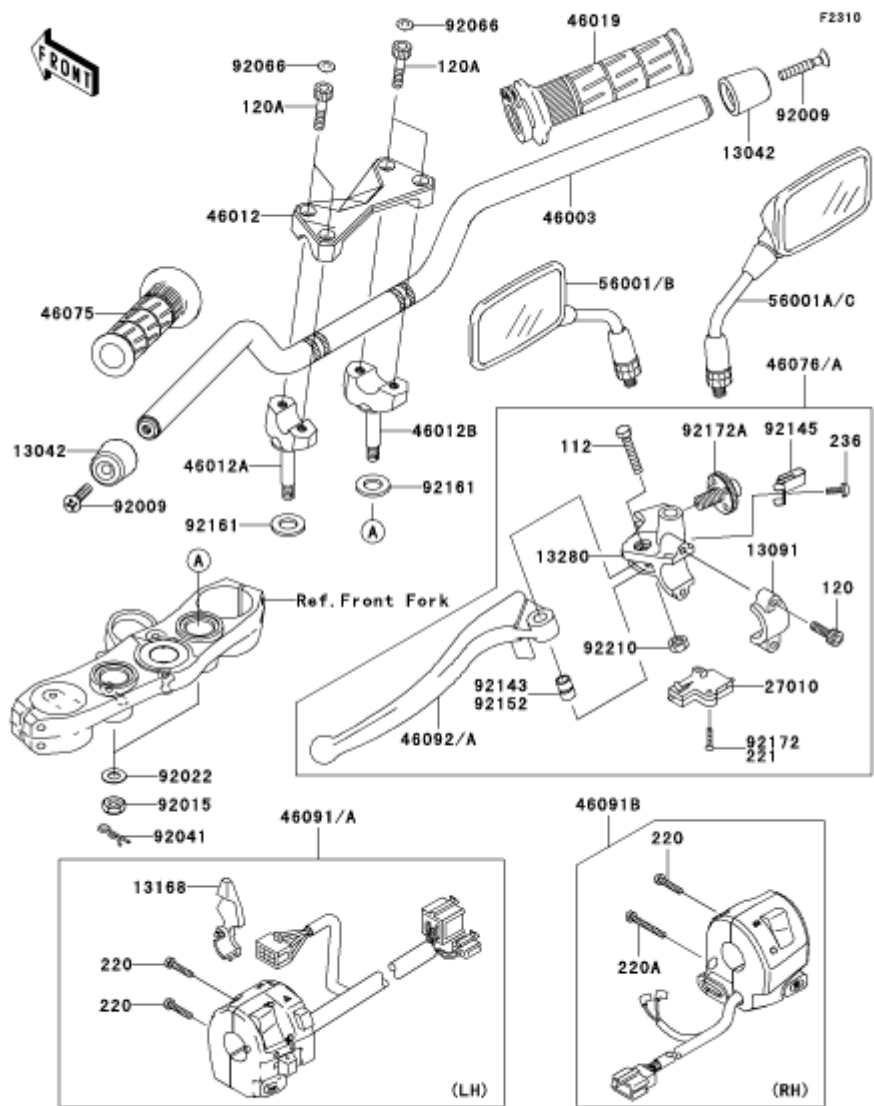

E1810

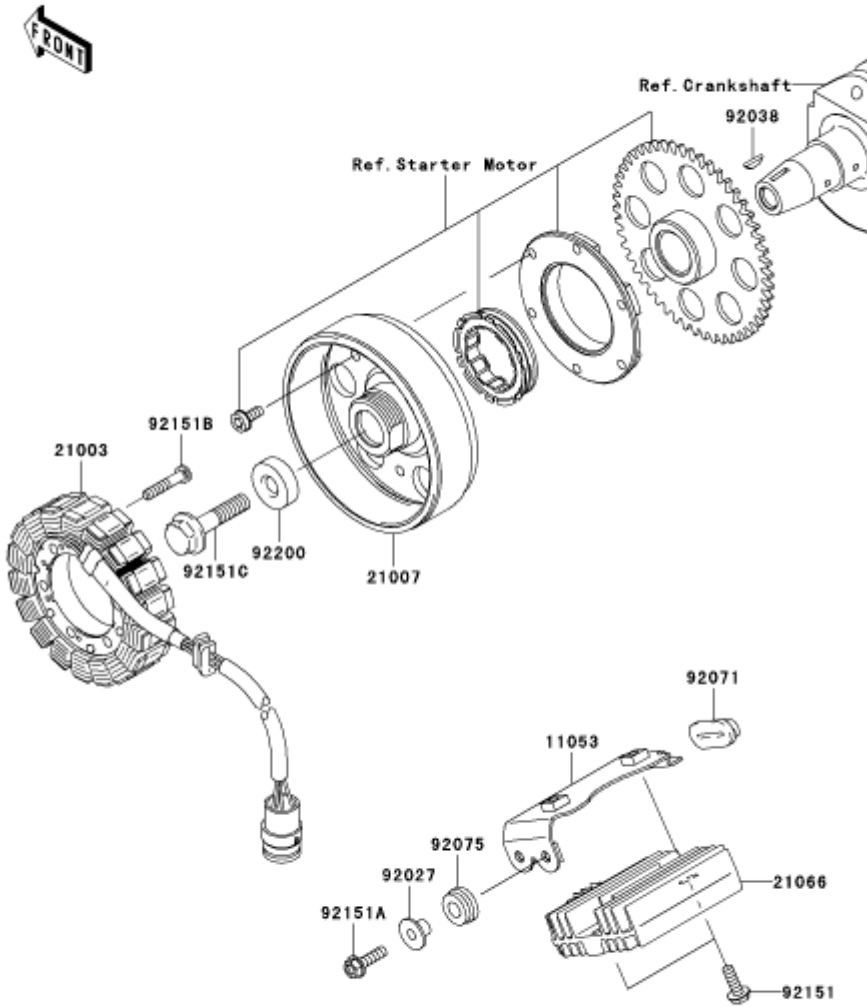

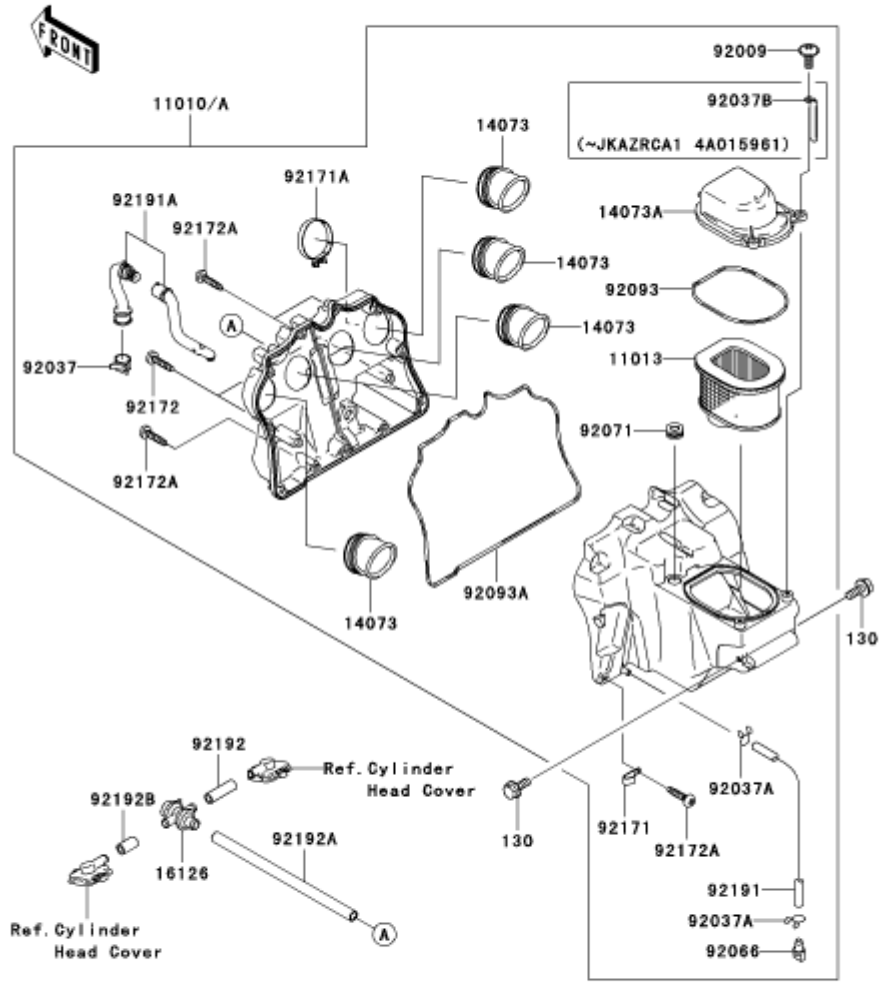

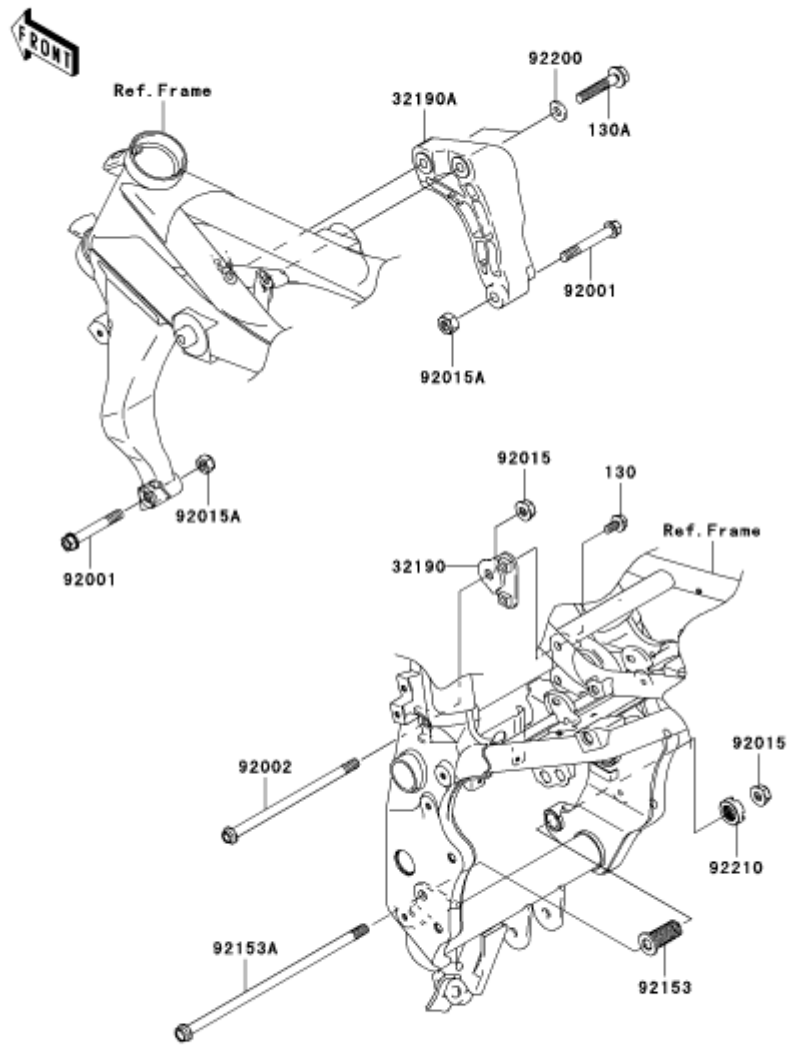

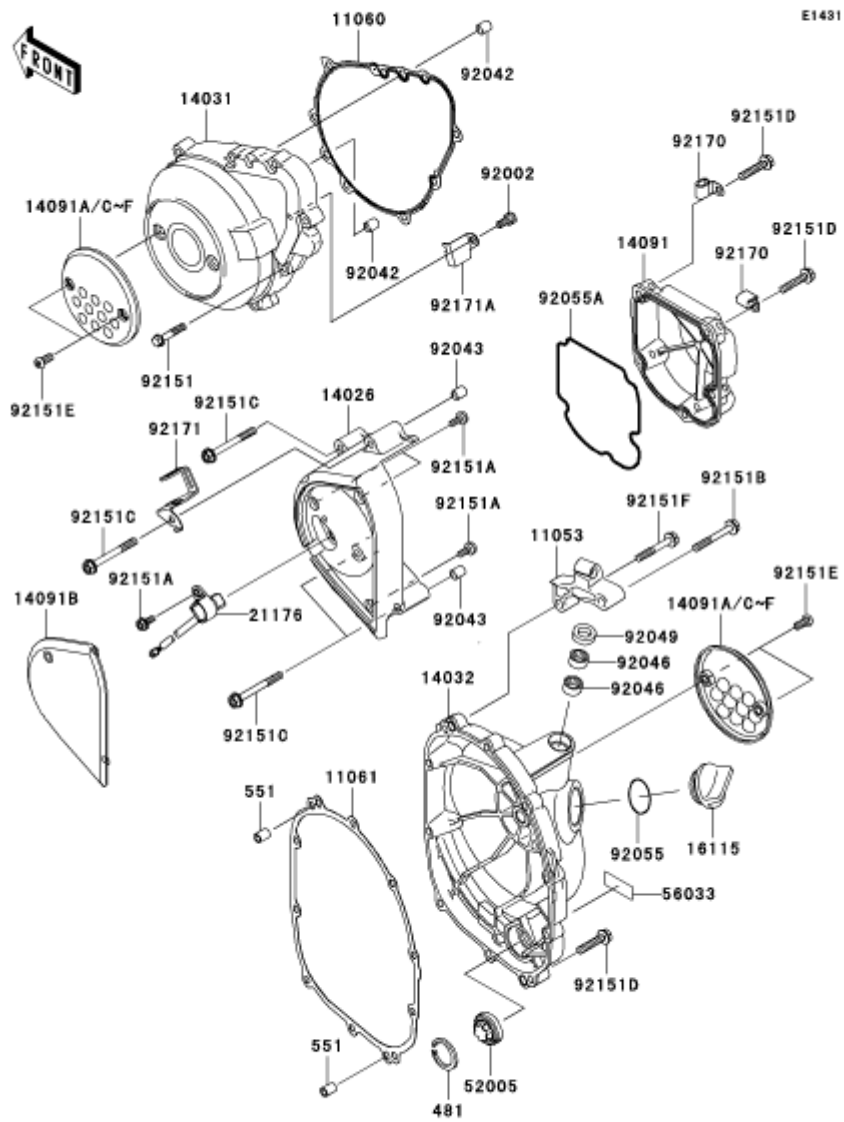

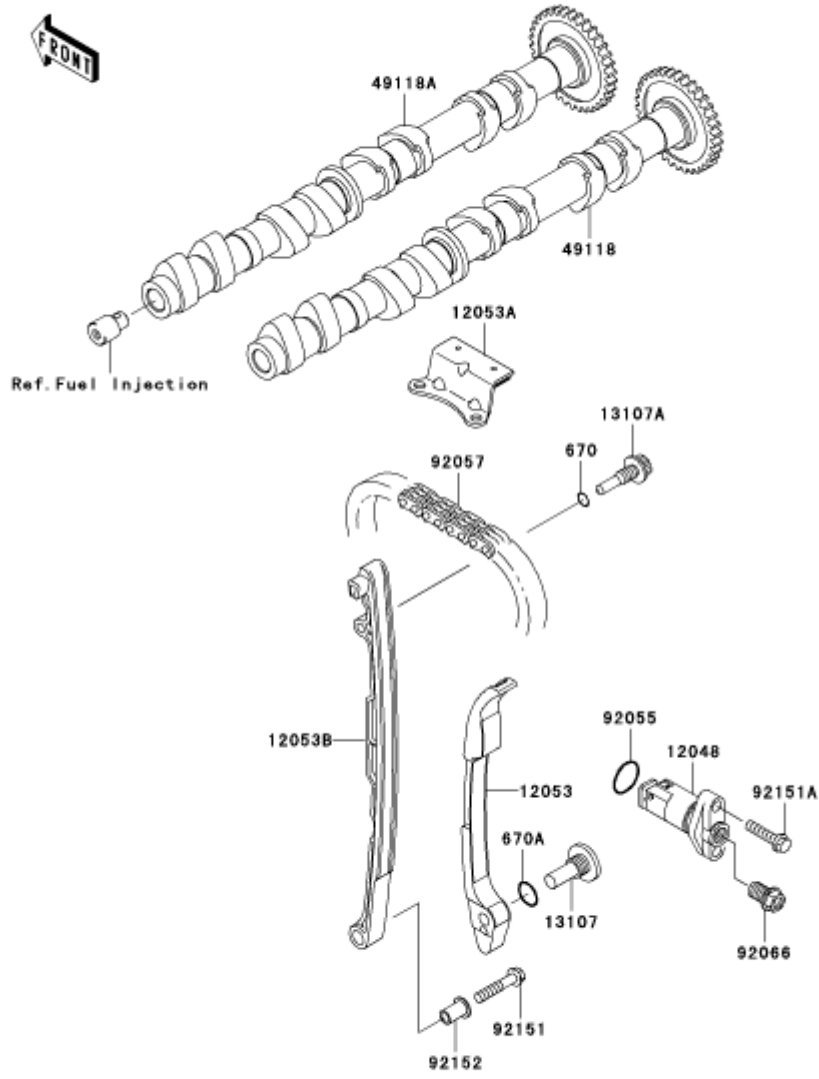

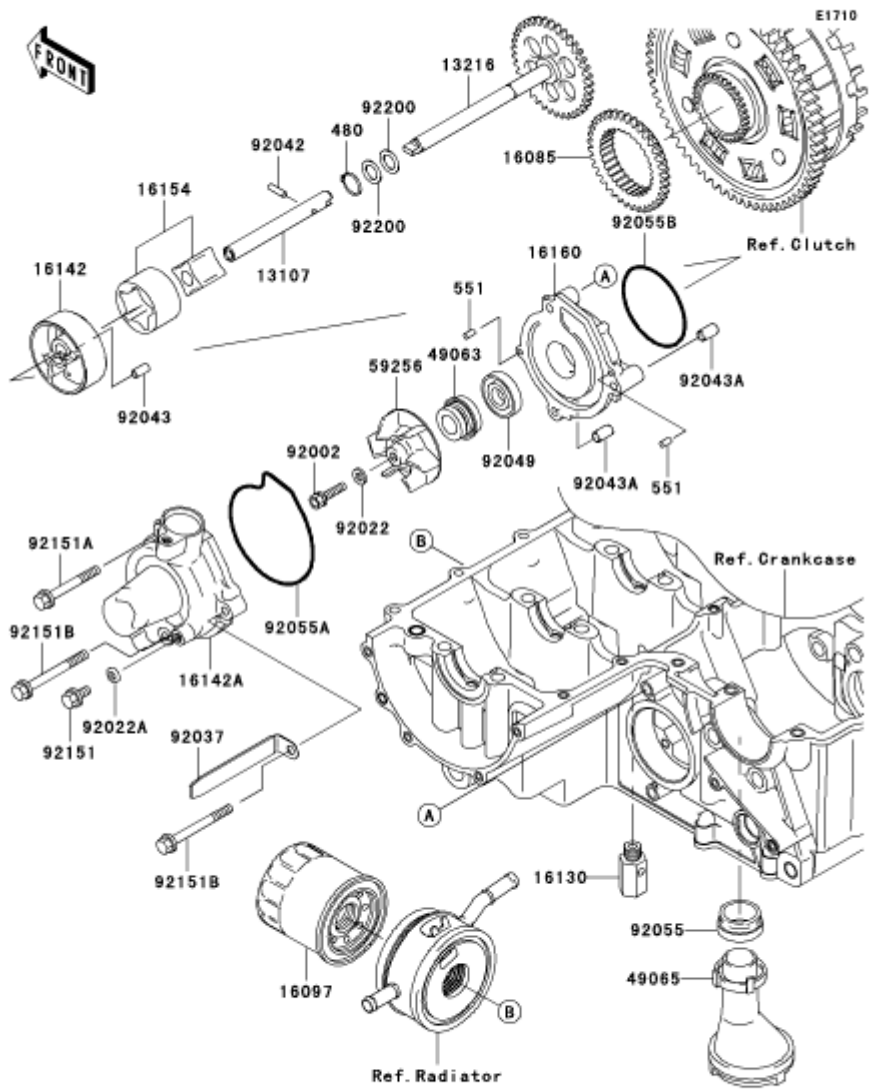

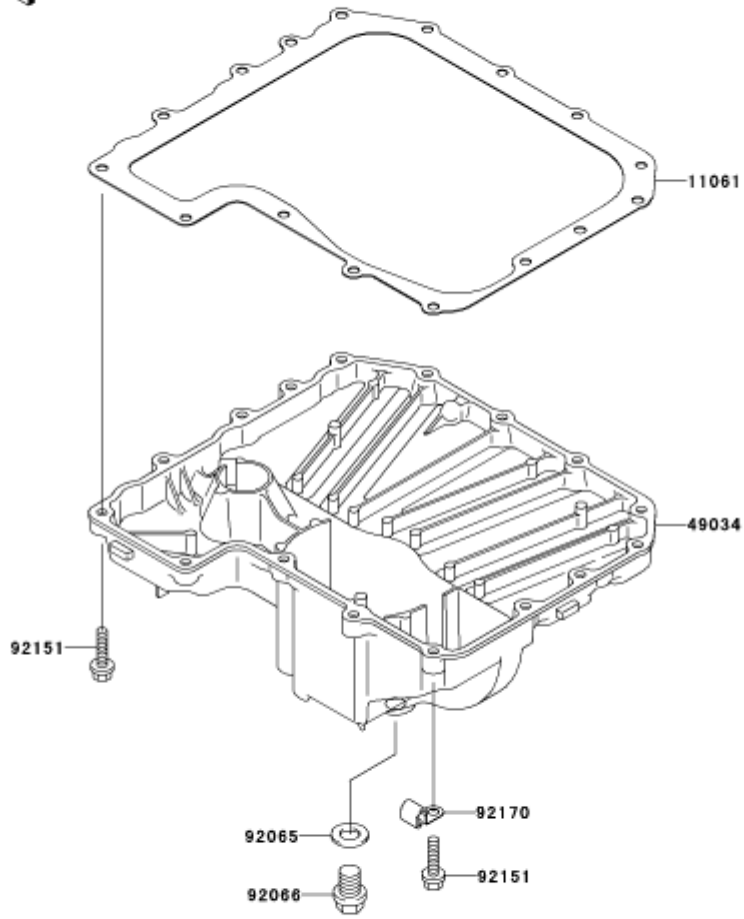

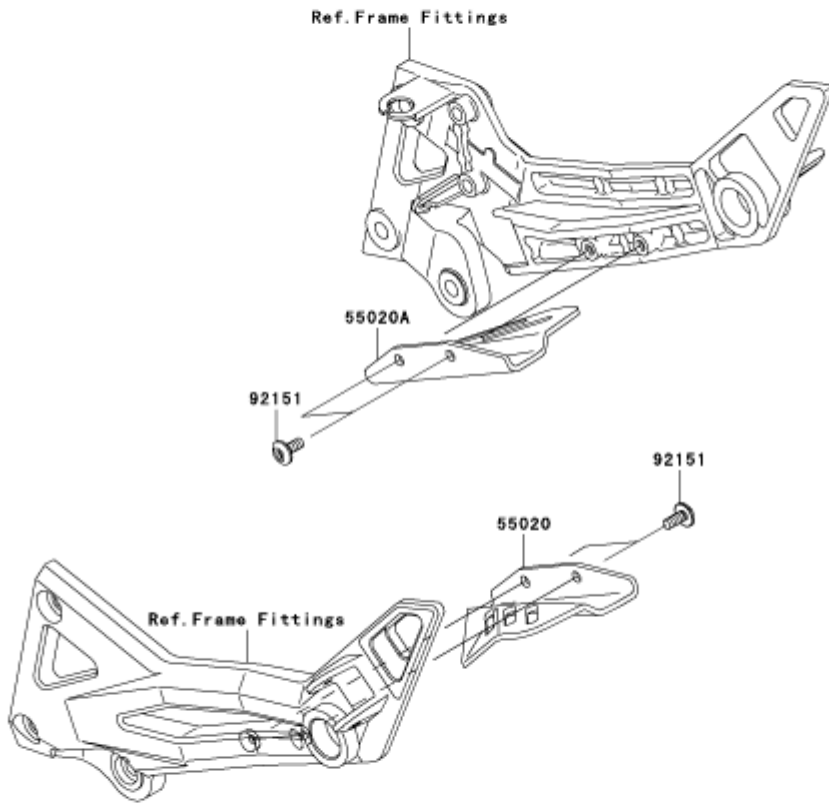

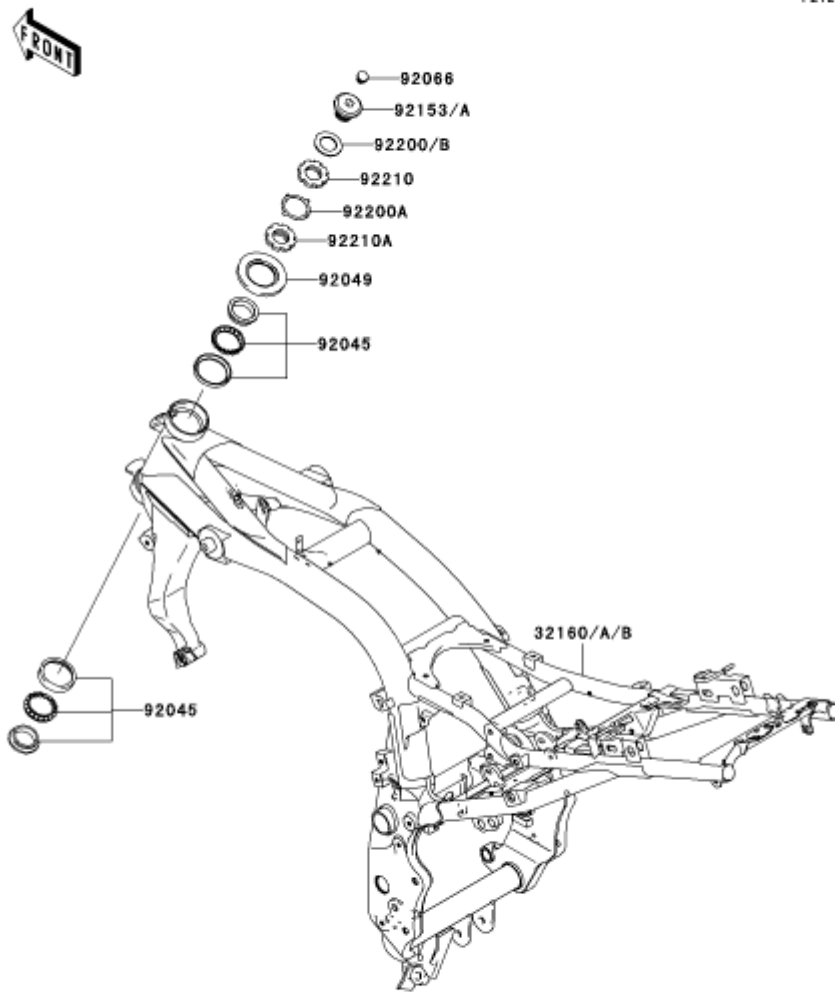

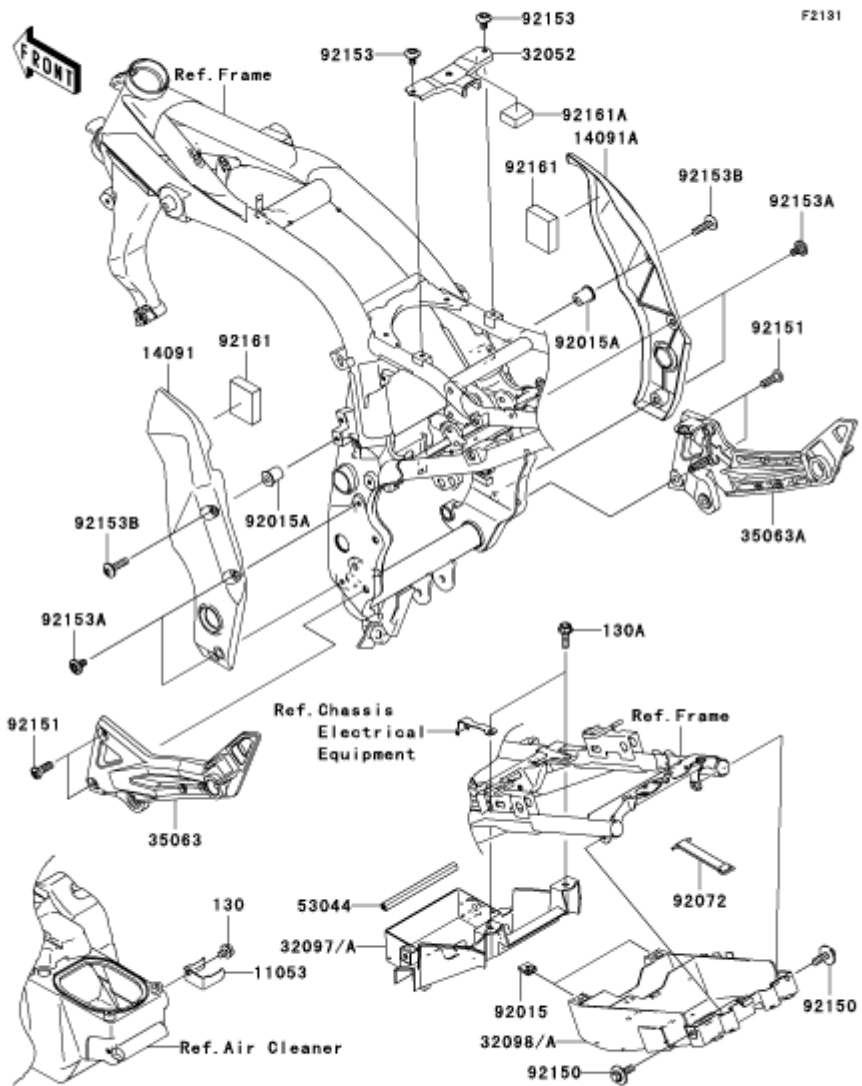

F2131

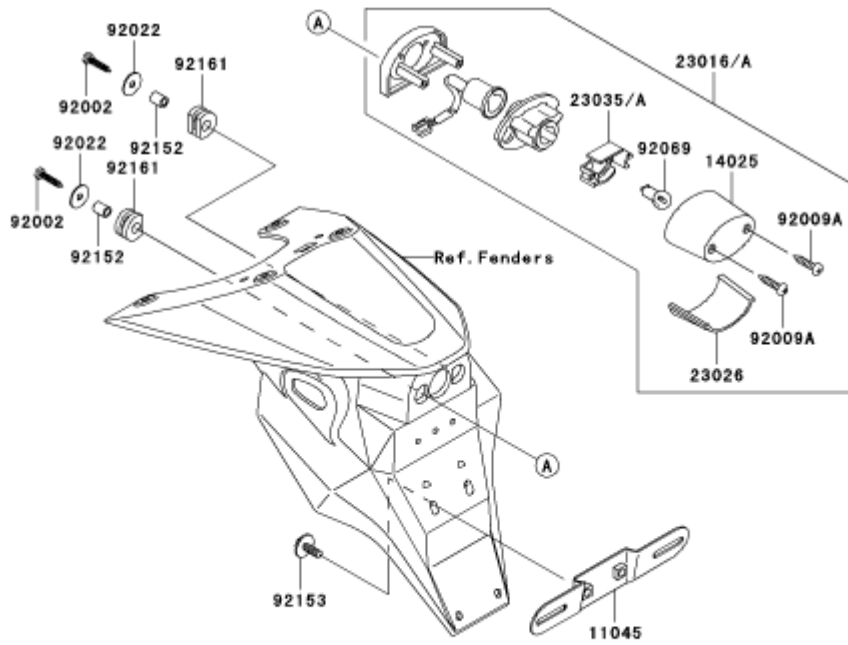
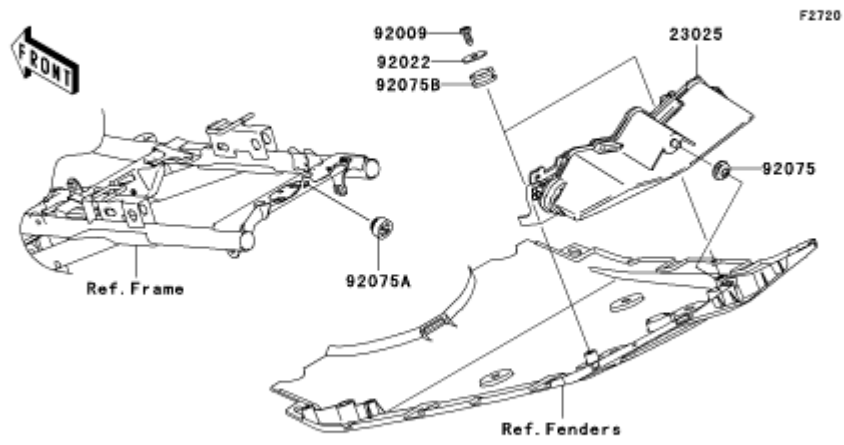

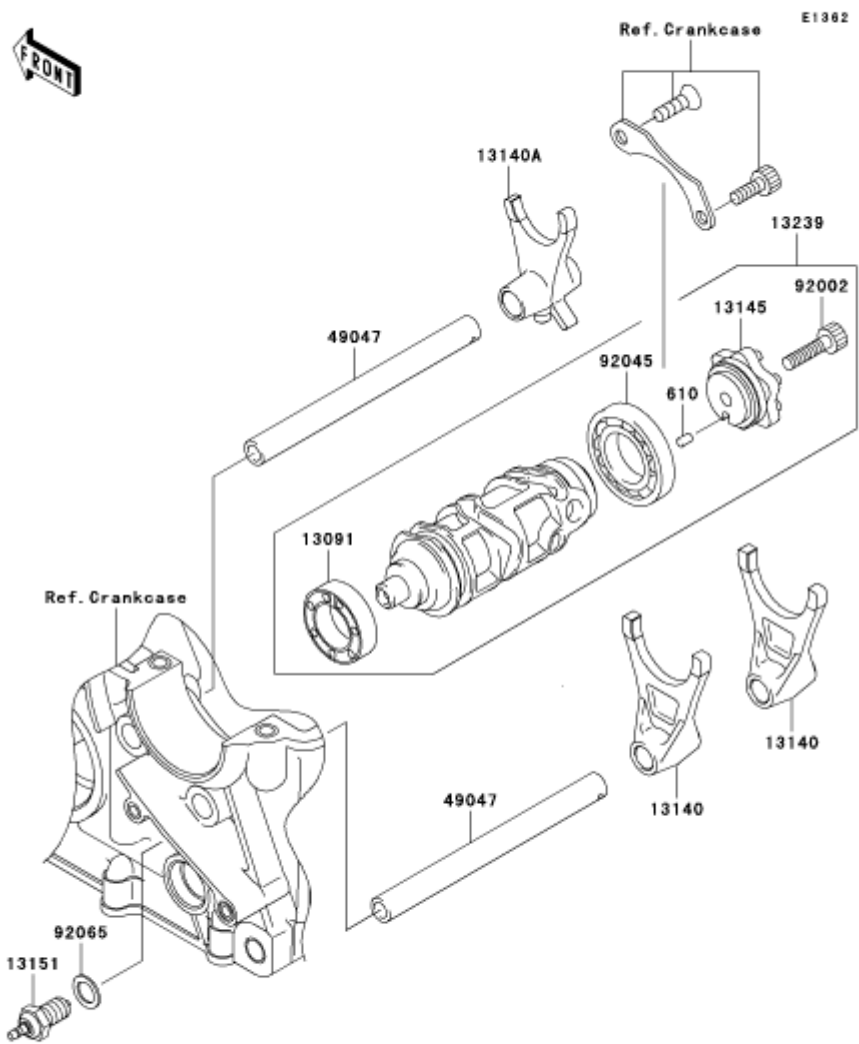

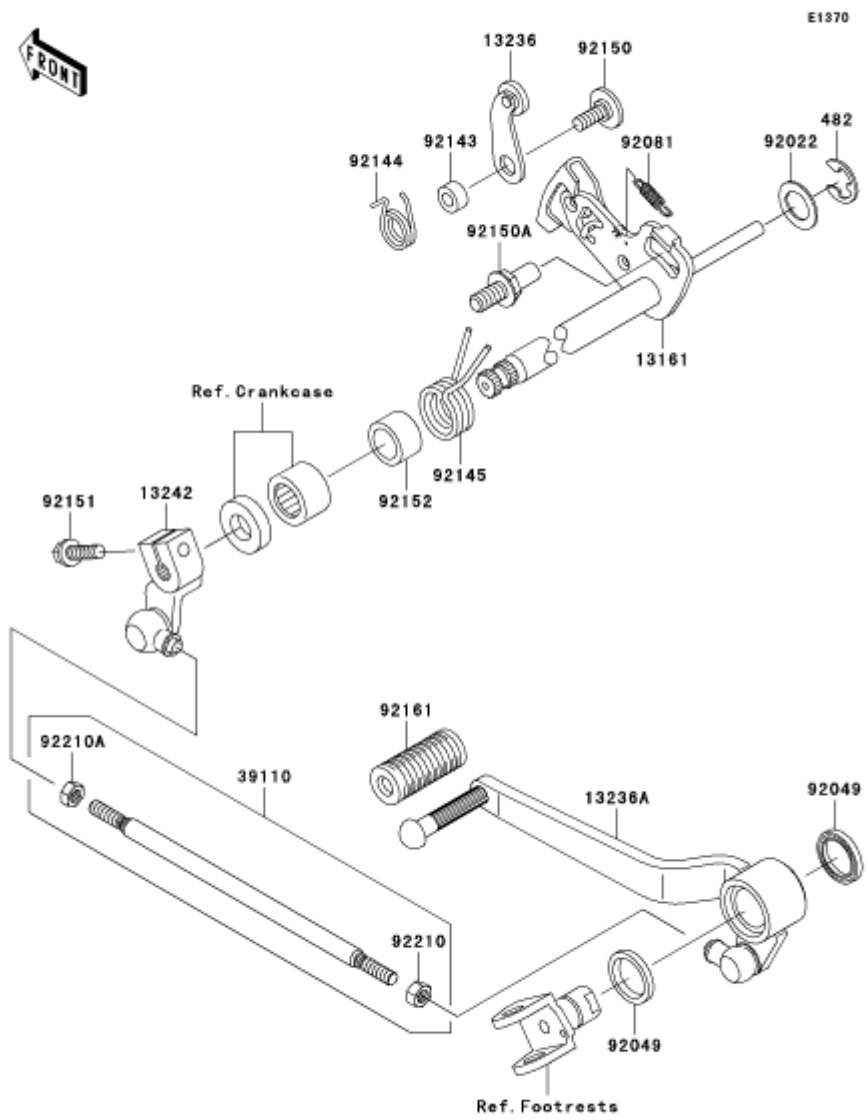



F2190

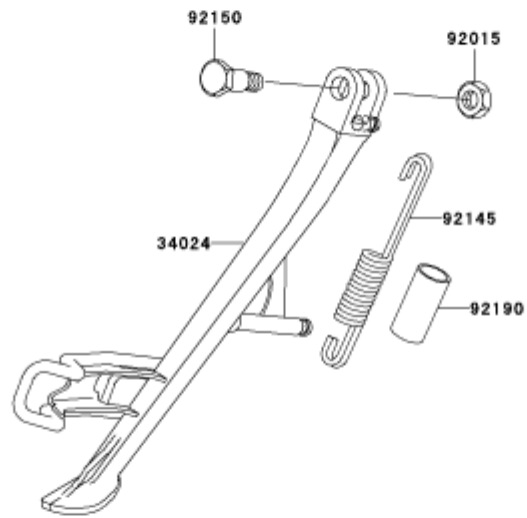

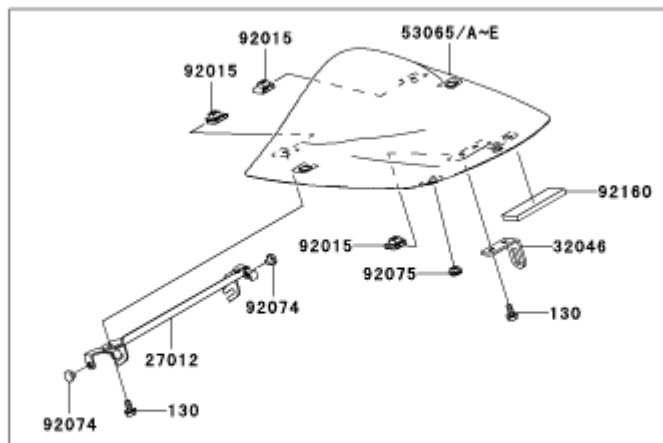
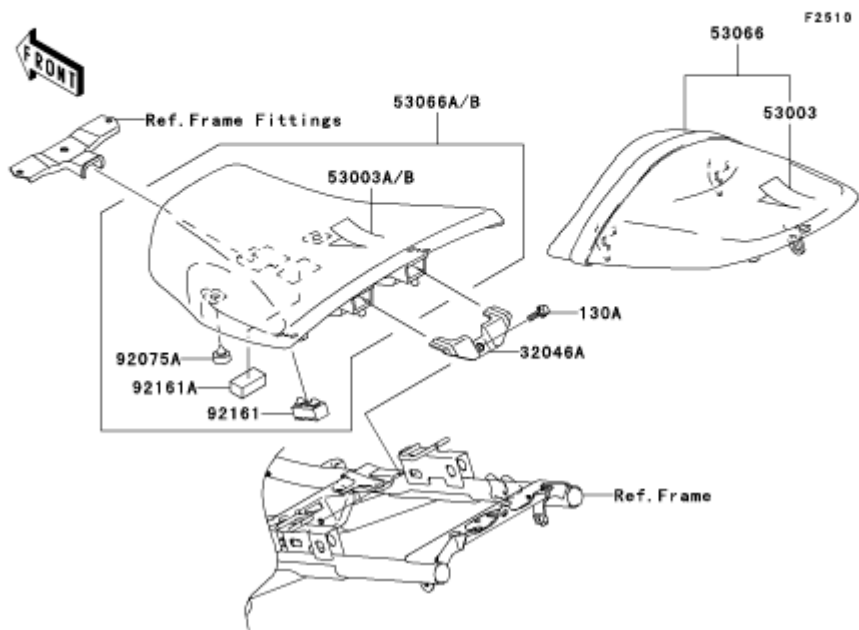

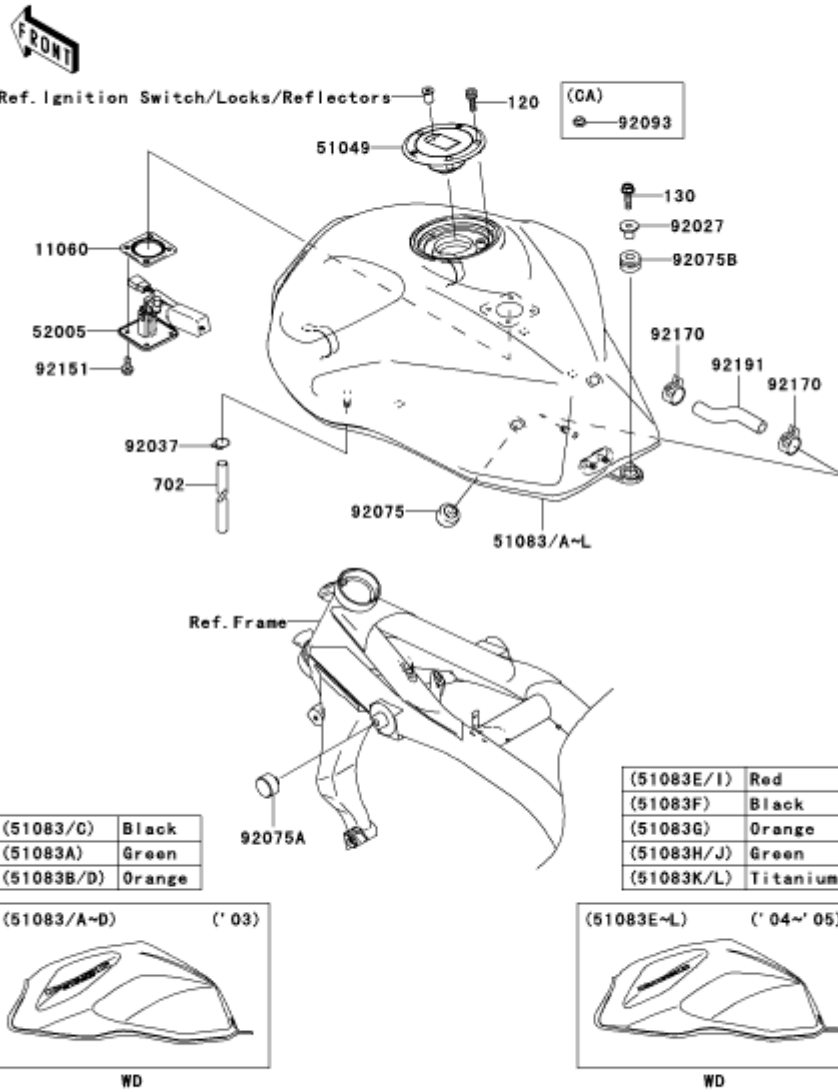

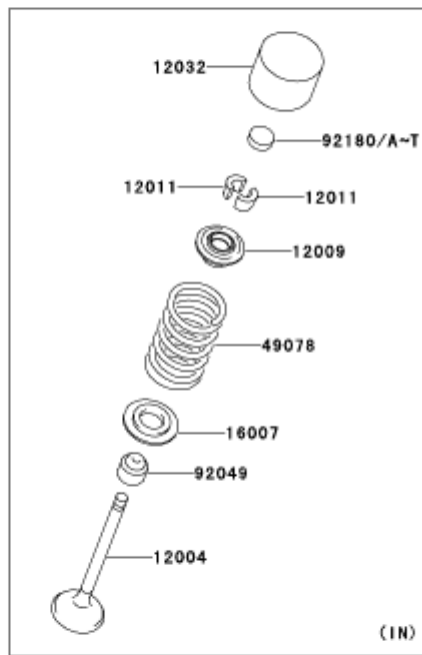
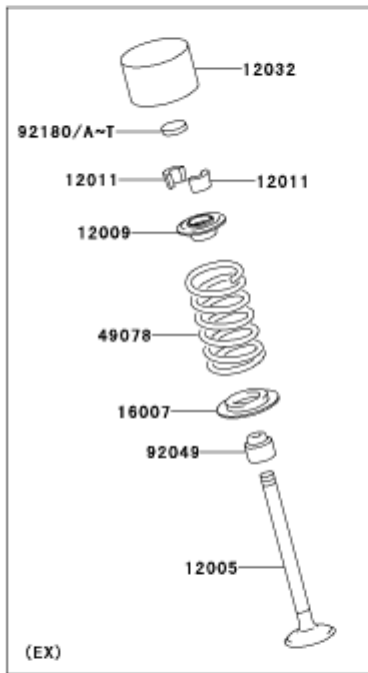

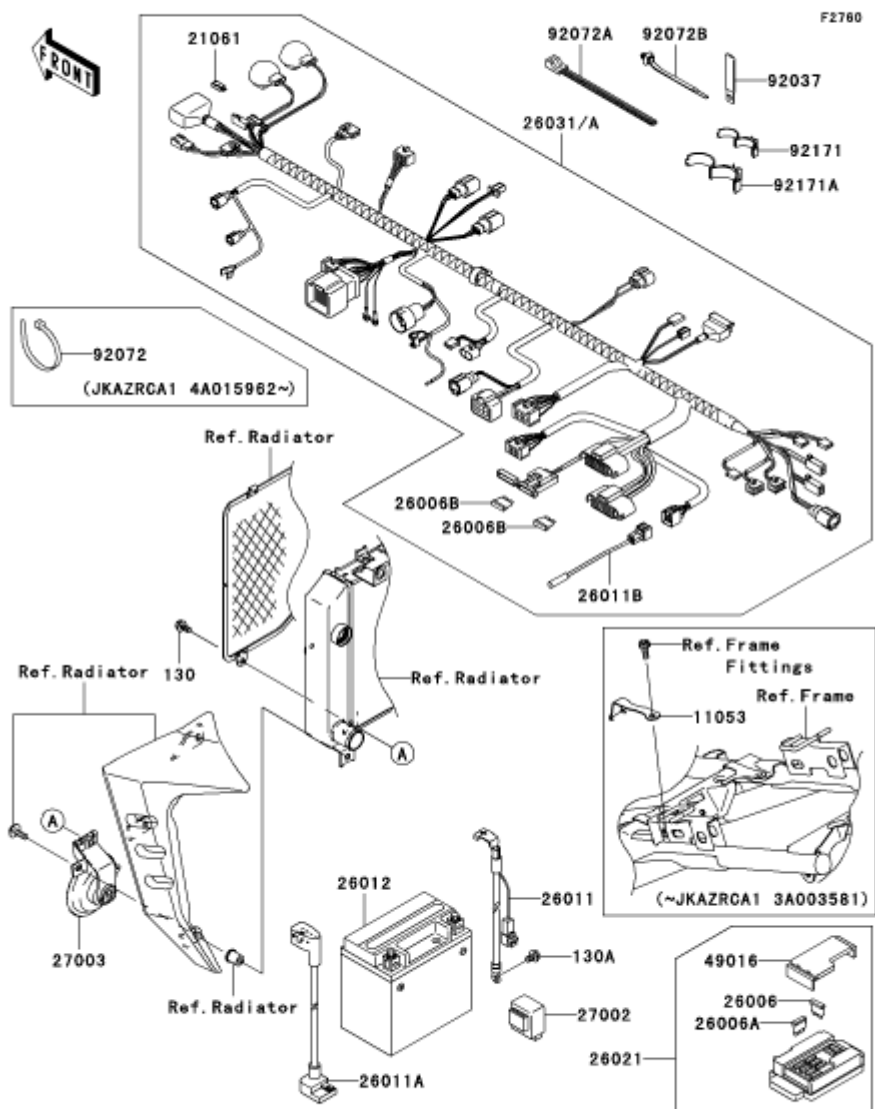

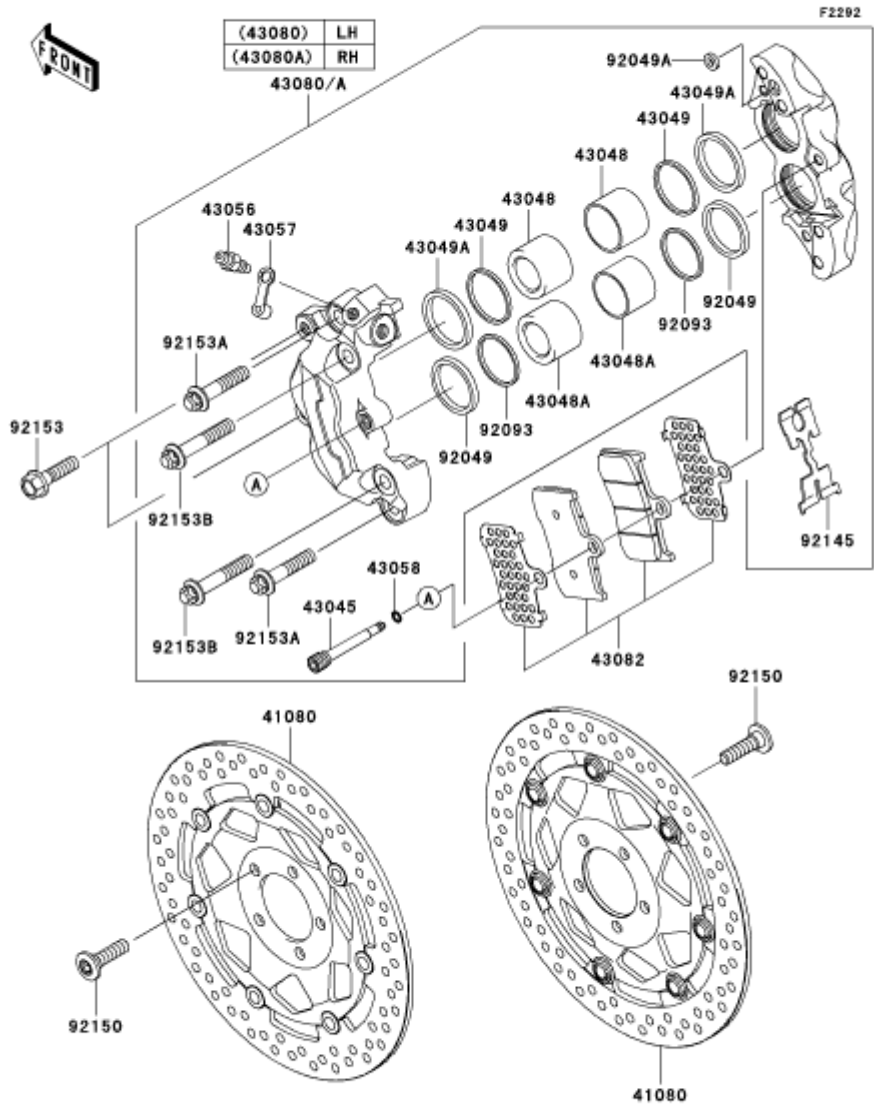

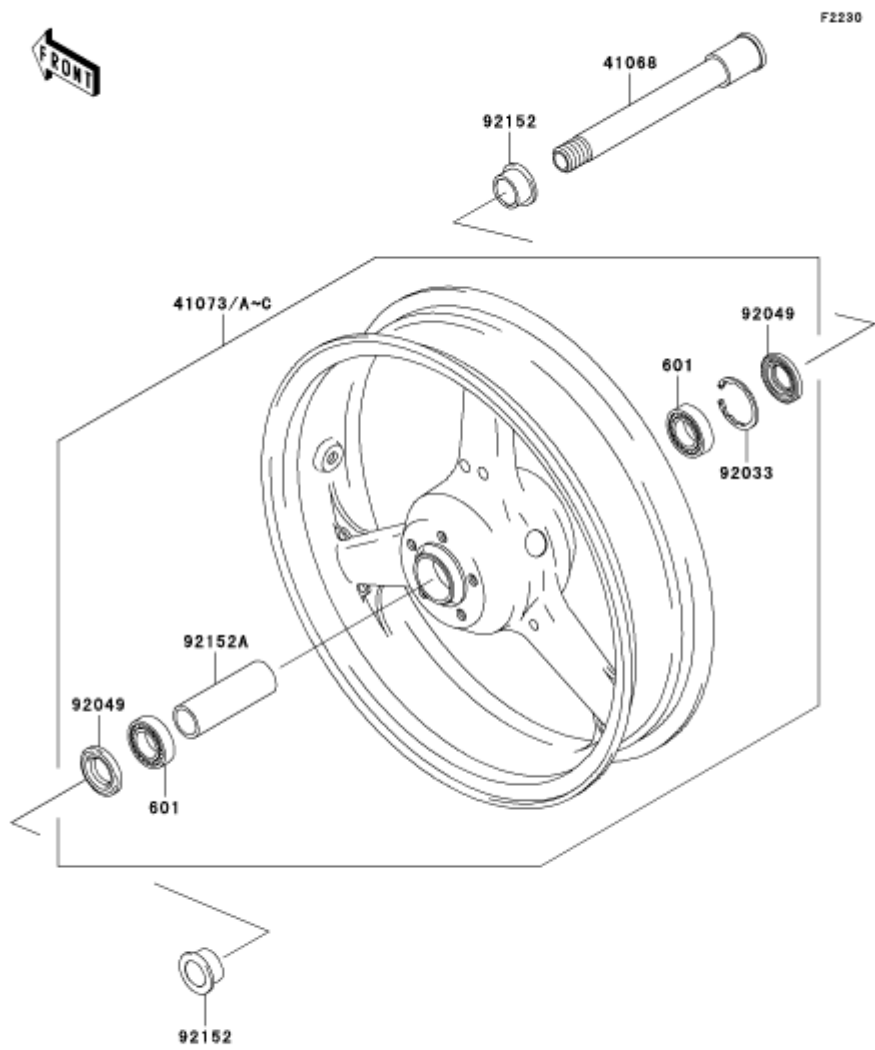

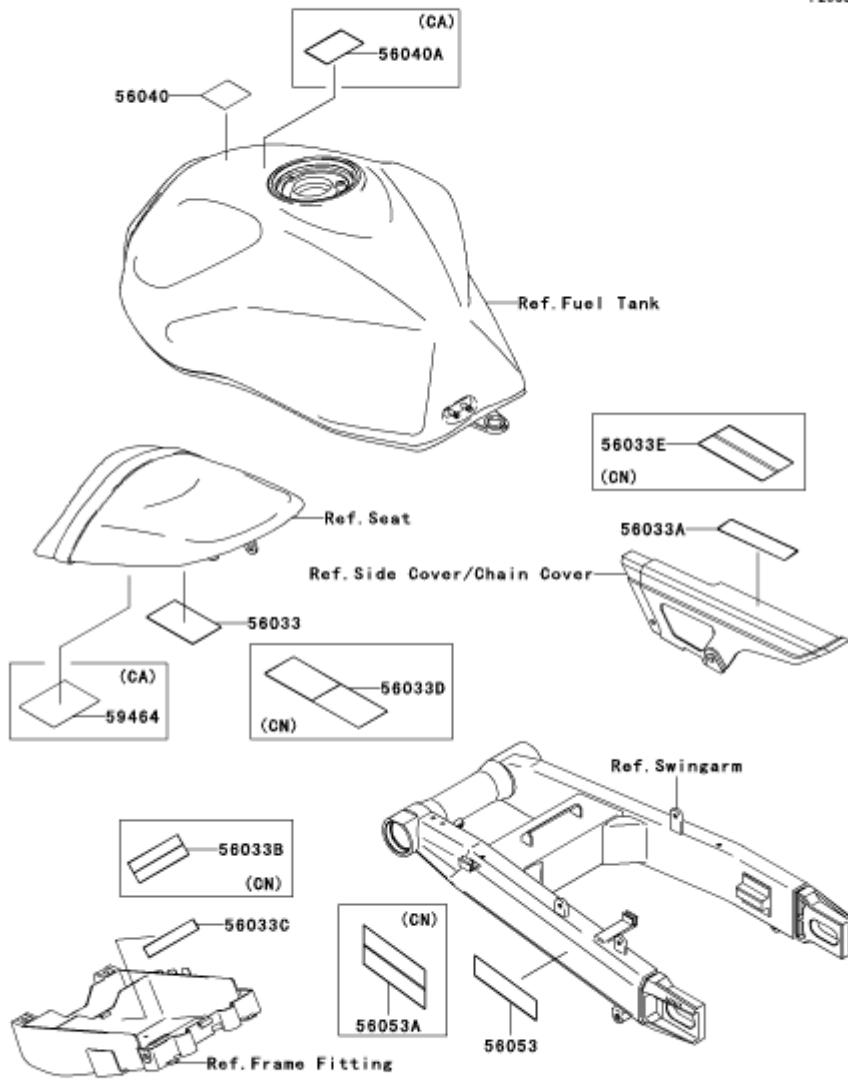

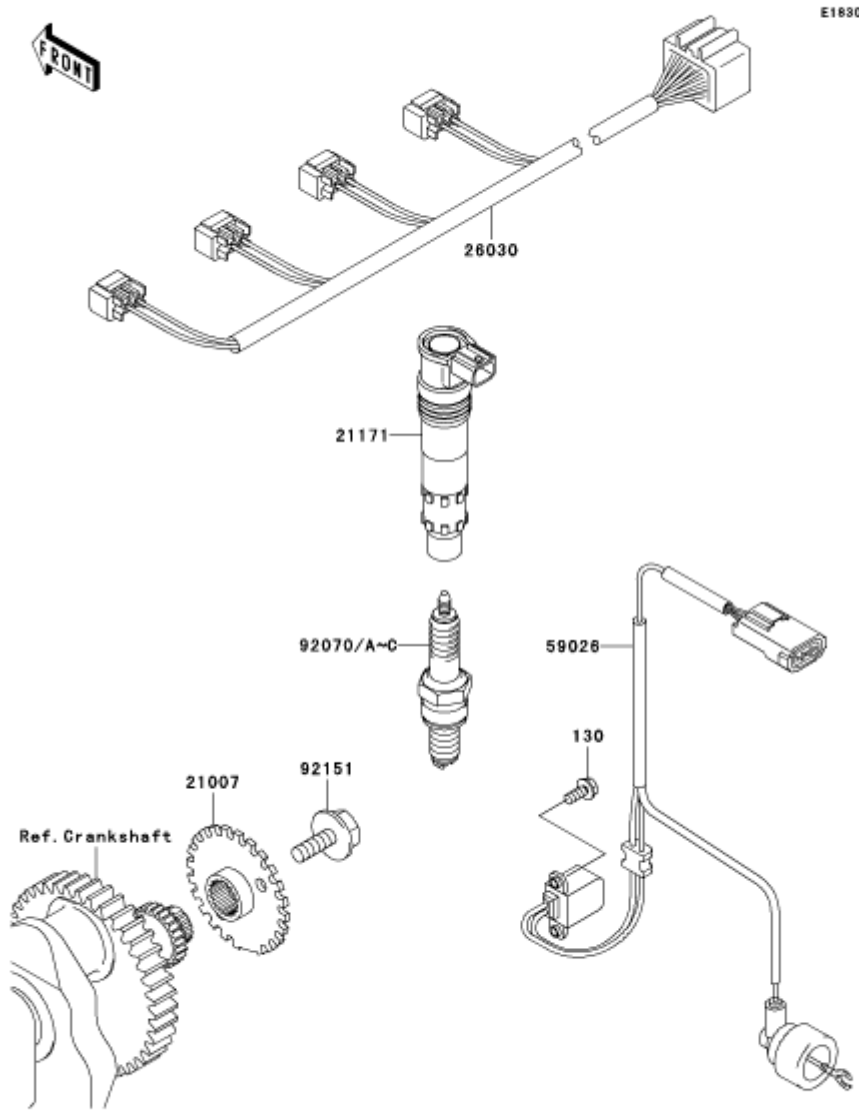

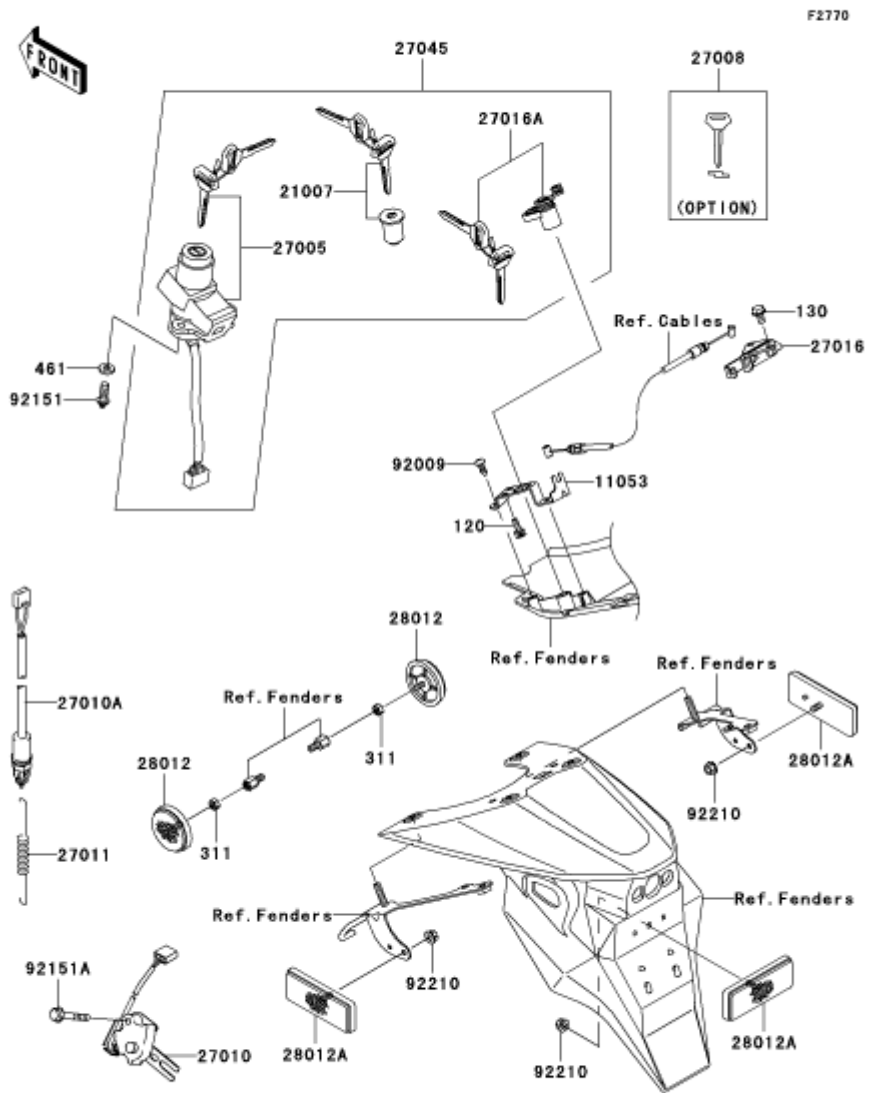

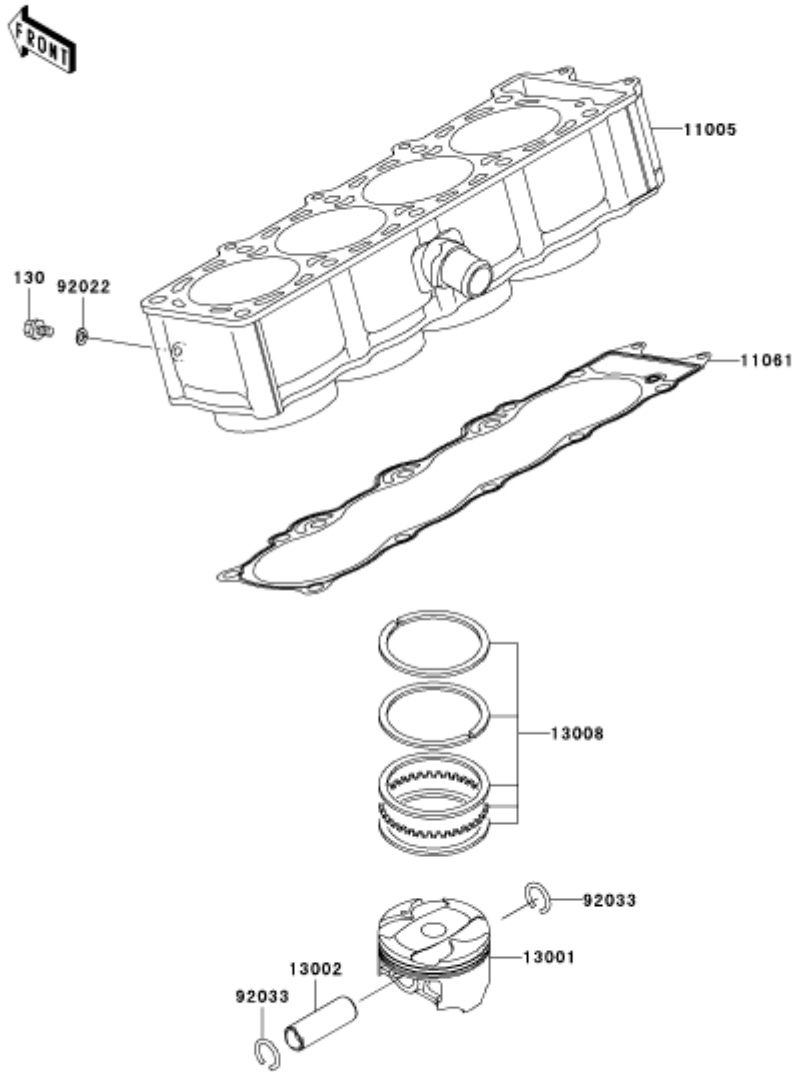

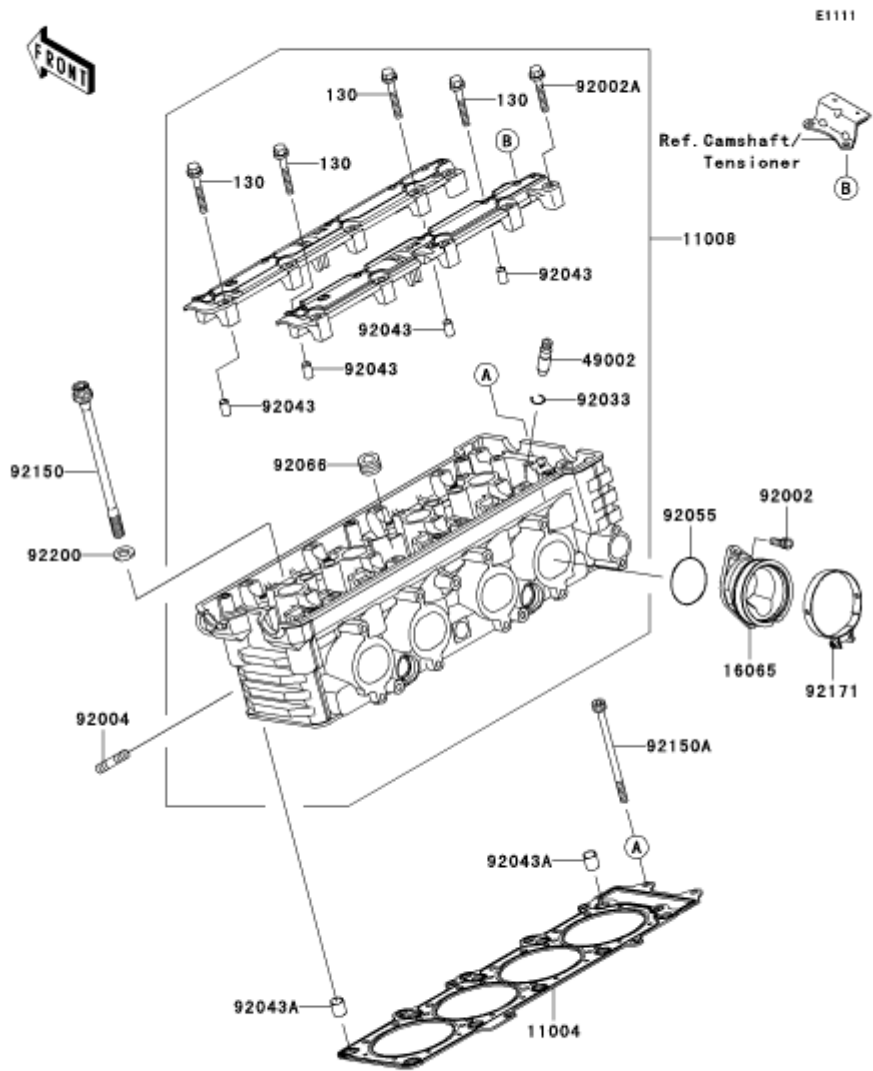

E1112

